

# bizhub C210

快速指南 [复印/打印/传真/扫描操作]



## 目录

- 前言
- 1. 基本操作
- 2. 有用的复印操作
- 3. 有用的打印操作
- 4. 有用的传真操作
- 5. 有用的网络扫描操作
- 6. 故障排除
- 7. 用户设置参数
- 8. 索引

## 本产品中有毒有害物质或元素的名称及含量（M1型）

部件名称	有毒有害物质或元素					
	铅 (Pb)	汞 (Hg)	镉 (Cd)	六价铬 (Cr(VI))	PBB	PBDE
机箱、底壳	○	○	○	○	○	○
打印配线板	×	○	○	○	○	○
液晶操作面板	×	×	○	○	○	○
电线	○	○	○	○	○	○
电子部件	×	○	×	○	○	○
金属部件	×	○	○	○	○	○

○：表示该有毒有害物质在该部件所有均质材料中的含量均在SJ/T11363-2006标准规定的限量要求以下。  
 ×：表示该有毒有害物质至少在该部件的某一均质材料中的含量超出SJ/T11363-2006标准规定的限量要求。

### 产品环保期限使用条件的注意事项



#### 产品环保使用期限的使用条件

在中国销售的电子信息产品的环保使用期限。表示按照本产品的安全使用注意事项使用的情况下，从生产日开始，在标志的年限内使用，本产品含有的有毒有害物质或元素不会对环境、人身和财产造成严重影响。

## 柯尼卡美能达产品“供应保证”项目

再次感谢您选择柯尼卡美能达产品。为了更好地为您服务，并满足您的不时之需，我们郑重承诺：

- ① 对于您购买的本产品保持正常操作性能，我们作出一年的承诺或规定的复印张数（以先到为准）。“规定的复印张数”请参考保修卡中的《保修细则》。
- ② 在停止生产本机型5年之内，我们保证供应（保修期外为有偿供应）本产品在正常使用范围内可能损坏的零部件，超过使用寿命的零部件不在其列。
- ③ 在停止生产本机型5年之内，我们保证有偿供应本产品的消耗品。

本承诺中涉及保修内容的条款，以保修卡中的《保修细则》为准。柯尼卡美能达办公系统（中国）有限公司保留对以上承诺的最终解释和更改的权利。

## 柯尼卡美能达产品“中国能效标识”项目

依据GB21521-2008《复印机能效限定值及能效等级》的技术要求,本机的具体数据请见下表:

型号	典型能源效率	关闭状态能耗	等级
C210	6.77	0.1	1 级

## 柯尼卡美能达产品回收·再利用项目

柯尼卡美能达办公系统（中国）有限公司对柯尼卡美能达品牌的复合机及打印机产品进行回收·再利用。这项服务是针对中国国内的用户使用完的柯尼卡美能达品牌的复合机及打印机产品及相应的消耗品实施的。

柯尼卡美能达办公系统（中国）有限公司将回收的产品及消耗品收集起来送交资源回收公司，通过资源回收公司进行分解再处理，最终作为原材料被再利用。

有关中国国内的此项服务内容，详细请访问

KONICA MINOLTA CHINA “<http://konicaminolta.com.cn/>”

## 再生复印纸

本产品可使用由100%的废纸生产的再生复印纸。但由于再生复印纸种类繁多，不排除有不适用的可能性。

---

## 前言

本快速指南 [复印 / 打印 / 传真 / 扫描操作] 以简单易懂的方式用插图介绍了最经常使用功能的操作步骤。

使用本说明书来熟悉本机所提供的有用功能。

有关各种功能的详细资料，请参见本机所附带使用说明书 CD 上的使用说明书。

为了安全、正确地操作本机，在使用之前请务必阅读本说明书上第 x-29 页的安全信息。

有关商标和版权的说明，请参见本说明的第 x-3 页。

另外，本说明书包含以下信息。使用机器前请务必阅读说明书。

- 为了安全使用本机必须遵守的事项
- 有关产品安全的信息
- 使用本机时的注意事项

本说明书所用的示意图可能与实际设备的外观略有不同。



作为 ENERGY STAR® 的合作伙伴，我们已确定本机符合关于节能的“ENERGY STAR® 指导规范”。

什么是 ENERGY STAR® 产品？

ENERGY STAR® 产品具有一个特性，在经过一段无活动时间后，它能自动切换到“节能模式”。ENERGY STAR® 产品利用能源的效率更高，可以帮助节省公共事业收费并有助于保护环境。

---

## 商标 / 版权所有

KONICA MINOLTA、KONICA MINOLTA 标识、以及 The essentials of imaging 是柯尼卡美能达控股株式会社的注册商标。

bizhub 是柯尼卡美能达商用科技株式会社的注册商标或商标。

Netscape is a registered trademark of Netscape Communications Corporation in the United States and other countries.

Mozilla and Firefox are trademarks of the Mozilla Foundation.

Novell and Novell NetWare are registered trademarks of Novell, Inc. in the United States and other countries.

Microsoft, Windows, and Windows NT are either registered trademarks or trademarks of Microsoft Corporation in the United States and/or other countries.

PowerPC is a trademark of IBM Corporation in the United States, or other countries, or both.

Apple, Macintosh and Mac OS are registered trademarks of Apple Computer, Inc. Safari is a trademark of Apple Computer, Inc.

Adobe, the Adobe logo, Acrobat and PostScript are either registered trademarks or trademarks of Adobe Systems Incorporated in the United States and/or other countries.

Ethernet is a registered trademark of Xerox Corporation.

PCL is a registered trademark of Hewlett-Packard Company Limited.

RC4<sup>®</sup> is a registered trademark or trademark of RSA Security Inc. in the United States and/or other countries.

RSA<sup>®</sup> is a registered trademark or trademark of RSA Security Inc. RSA BSAFE<sup>®</sup> is a registered trademark or trademark of RSA Security Inc. in the United States and/or other countries.



License information

This product includes RSA BSAFE Cryptographic software from RSA Security Inc.

所有其它产品和商标名是其各自公司或组织的商标或注册商标。

## 关于每个软件组件的许可证

本产品包含的一部分软件组件已被授予了 GPL、LGPL 或其他许可证。非常感谢软件作者以及致力于有关软件的数据管理和其他活动的团队成员。

下面所述的 GPL/LGPL 用来保证用户在需要时可以接收到源代码。有关详细资料，请访问我们的网站：  
<http://konicaminolta.com/opensource/>

由于我们软件的组件不是开源软件，我们将不提供源代码，希望您能够理解。

下面是授予本产品中所包含软件组件的 GPL、LGPL 和其它许可证原文的副本。

Apple Public Source License

Apache License, Version 2.0

krb5-libs License

zlib/libpng License

Pure-FTPd License

OpenSLP License

Net-SNMP License

cyrus-sasl License

dhclient License

expat License

OpenSSL License

### **The GNU General Public License (GPL)**

Version 2, June 1991

Copyright © 1989, 1991 Free Software Foundation, Inc.  
59 Temple Place, Suite 330, Boston, MA 02111-1307 USA

Everyone is permitted to copy and distribute verbatim copies of this license document, but changing it is not allowed.

#### Preamble

The licenses for most software are designed to take away your freedom to share and change it. By contrast, the GNU General Public License is intended to guarantee your freedom to share and change free software--to make sure the software is free for all its users. This General Public License applies to most of the Free Software Foundation's software and to any other program whose authors commit to using it. (Some other Free Software Foundation software is covered by the GNU Library General Public License instead.) You can apply it to your programs, too.

When we speak of free software, we are referring to freedom, not price. Our General Public Licenses are designed to make sure that you have the freedom to distribute copies of free software (and charge for this service if you wish), that you receive source code or can get it if you want it, that you can change the software or use pieces of it in new free programs; and that you know you can do these things.

To protect your rights, we need to make restrictions that forbid anyone to deny you these rights or to ask you to surrender the rights. These restrictions translate to certain responsibilities for you if you distribute copies of the software, or if you modify it.

For example, if you distribute copies of such a program, whether gratis or for a fee, you must give the recipients all the rights that you have. You must make sure that they, too, receive or can get the source code. And you must show them these terms so they know their rights.

We protect your rights with two steps: (1) copyright the software, and (2) offer you this license which gives you legal permission to copy, distribute and/or modify the software.

Also, for each author's protection and ours, we want to make certain that everyone understands that there is no warranty for this free software. If the software is modified by someone else and passed on, we want its recipients to know that what they have is not the original, so that any problems introduced by others will not reflect on the original authors' reputations.

Finally, any free program is threatened constantly by software patents. We wish to avoid the danger that redistributors of a free program will individually obtain patent licenses, in effect making the program proprietary. To prevent this, we have made it clear that any patent must be licensed for everyone's free use or not licensed at all.

The precise terms and conditions for copying, distribution and modification follow.

---

## TERMS AND CONDITIONS FOR COPYING, DISTRIBUTION AND MODIFICATION

0. This License applies to any program or other work which contains a notice placed by the copyright holder saying it may be distributed under the terms of this General Public License. The "Program", below, refers to any such program or work, and a "work based on the Program" means either the Program or any derivative work under copyright law: that is to say, a work containing the Program or a portion of it, either verbatim or with modifications and/or translated into another language. (Hereinafter, translation is included without limitation in the term "modification".) Each licensee is addressed as "you".

Activities other than copying, distribution and modification are not covered by this License; they are outside its scope. The act of running the Program is not restricted, and the output from the Program is covered only if its contents constitute a work based on the Program (independent of having been made by running the Program). Whether that is true depends on what the Program does.

1. You may copy and distribute verbatim copies of the Program's source code as you receive it, in any medium, provided that you conspicuously and appropriately publish on each copy an appropriate copyright notice and disclaimer of warranty; keep intact all the notices that refer to this License and to the absence of any warranty; and give any other recipients of the Program a copy of this License along with the Program.

You may charge a fee for the physical act of transferring a copy, and you may at your option offer warranty protection in exchange for a fee.

2. You may modify your copy or copies of the Program or any portion of it, thus forming a work based on the Program, and copy and distribute such modifications or work under the terms of Section 1 above, provided that you also meet all of these conditions:

a) You must cause the modified files to carry prominent notices stating that you changed the files and the date of any change.)

b) You must cause any work that you distribute or publish, that in whole or in part contains or is derived from the Program or any part thereof, to be licensed as a whole at no charge to all third parties under the terms of this License.

c) If the modified program normally reads commands interactively when run, you must cause it, when started running for such interactive use in the most ordinary way, to print or display an announcement including an appropriate copyright notice and a notice that there is no warranty (or else, saying that you provide a warranty) and that users may redistribute the program under these conditions, and telling the user how to view a copy of this License. (Exception: if the Program itself is interactive but does not normally print such an announcement, your work based on the Program is not required to print an announcement.)

These requirements apply to the modified work as a whole. If identifiable sections of that work are not derived from the Program, and can be reasonably considered independent and separate works in themselves, then this License, and its terms, do not apply to those sections when you distribute them as separate works. But when you distribute the same sections as part of a whole which is a work based on the Program, the distribution of the whole must be on the terms of this License, whose permissions for other licensees extend to the entire whole, and thus to each and every part regardless of who wrote it.

Thus, it is not the intent of this section to claim rights or contest your rights to work written entirely by you; rather, the intent is to exercise the right to control the distribution of derivative or collective works based on the Program.

In addition, mere aggregation of another work not based on the Program with the Program (or with a work based on the Program) on a volume of a storage or distribution medium does not bring the other work under the scope of this License.

3. You may copy and distribute the Program (or a work based on it, under Section 2) in object code or executable form under the terms of Sections 1 and 2 above provided that you also do one of the following:

a) Accompany it with the complete corresponding machine-readable source code, which must be distributed under the terms of Sections 1 and 2 above on a medium customarily used for software interchange; or,

b) Accompany it with a written offer, valid for at least three years, to give any third party, for a charge no more than your cost of physically performing source distribution, a complete machine-readable copy of the corresponding source code, to be distributed under the terms of Sections 1 and 2 above on a medium customarily used for software interchange; or,

c) Accompany it with the information you received as to the offer to distribute corresponding source code. (This alternative is allowed only for noncommercial distribution and only if you received the program in object code or executable form with such an offer, in accord with Subsection b above.)

The source code for a work means the preferred form of the work for making modifications to it. For an executable work, complete source code means all the source code for all modules it contains, plus any associated interface definition files, plus the scripts used to control compilation and installation of the executable. However, as a special exception, the source code distributed need not include anything that is normally distributed (in either source or binary form) with the major components (compiler, kernel, and so on) of the operating system on which the executable runs, unless that component itself accompanies the executable.

If distribution of executable or object code is made by offering access to copy from a designated place, then offering equivalent access to copy the source code from the same place counts as distribution of the source code, even though third parties are not compelled to copy the source along with the object code.

4. You may not copy, modify, sublicense, or distribute the Program except as expressly provided under this License. Any attempt otherwise to copy, modify, sublicense or distribute the Program is void, and will automatically terminate your rights under this License. However, parties who have received copies, or rights, from you under this License will not have their licenses terminated so long as such parties remain in full compliance.

5. You are not required to accept this License, since you have not signed it. However, nothing else grants you permission to modify or distribute the Program or its derivative works. These actions are prohibited by law if you do not accept this License. Therefore, by modifying or distributing the Program (or any work based on the Program), you indicate your acceptance of this License to do so, and all its terms and conditions for copying, distributing or modifying the Program or works based on it.

6. Each time you redistribute the Program (or any work based on the Program), the recipient automatically receives a license from the original licensor to copy, distribute or modify the Program subject to these terms and conditions. You may not impose any further restrictions on the recipients' exercise of the rights granted herein. You are not responsible for enforcing compliance by third parties to this License.

7. If, as a consequence of a court judgment or allegation of patent infringement or for any other reason (not limited to patent issues), conditions are imposed on you (whether by court order, agreement or otherwise) that contradict the conditions of this License, they do not excuse you from the conditions of this License. If you cannot distribute so as to satisfy simultaneously your obligations under this License and any other pertinent obligations, then as a consequence you may not distribute the Program at all. For example, if a patent license would not permit royalty-free redistribution of the Program by all those who receive copies directly or indirectly through you, then the only way you could satisfy both it and this License would be to refrain entirely from distribution of the Program.

If any portion of this section is held invalid or unenforceable under any particular circumstance, the balance of the section is intended to apply and the section as a whole is intended to apply in other circumstances.

It is not the purpose of this section to induce you to infringe any patents or other property right claims or to contest validity of any such claims; this section has the sole purpose of protecting the integrity of the free software distribution system, which is implemented by public license practices. Many people have made generous contributions to the wide range of software distributed through that system in reliance on consistent application of that system; it is up to the author/donor to decide if he or she is willing to distribute software through any other system and a licensee cannot impose that choice.

This section is intended to make thoroughly clear what is believed to be a consequence of the rest of this License.

8. If the distribution and/or use of the Program is restricted in certain countries either by patents or by copyrighted interfaces, the original copyright holder who places the Program under this License may add an explicit geographical distribution limitation excluding those countries, so that distribution is permitted only in or among countries not thus excluded. In such case, this License incorporates the limitation as if written in the body of this License.

9. The Free Software Foundation may publish revised and/or new versions of the General Public License from time to time. Such new versions will be similar in spirit to the present version, but may differ in detail to address new problems or concerns.

Each version is given a distinguishing version number. If the Program specifies a version number of this License which applies to it and "any later version", you have the option of following the terms and conditions either of that version or of any later version published by the Free Software Foundation. If the Program does not specify a version number of this License, you may choose any version ever published by the Free Software Foundation.

10. If you wish to incorporate parts of the Program into other free programs whose distribution conditions are different, write to the author to ask for permission. For software which is copyrighted by the Free Software Foundation, write to the Free Software Foundation; we sometimes make exceptions for this. Our decision will be guided by the two goals of preserving the free status of all derivatives of our free software and of promoting the sharing and reuse of software generally.



## NO WARRANTY

11. BECAUSE THE PROGRAM IS LICENSED FREE OF CHARGE, THERE IS NO WARRANTY FOR THE PROGRAM, TO THE EXTENT PERMITTED BY APPLICABLE LAW. EXCEPT WHEN OTHERWISE STATED IN WRITING THE COPYRIGHT HOLDERS AND/OR OTHER PARTIES PROVIDE THE PROGRAM "AS IS" WITHOUT WARRANTY OF ANY KIND, EITHER EXPRESSED OR IMPLIED, INCLUDING, BUT NOT LIMITED TO, THE IMPLIED WARRANTIES OF MERCHANTABILITY AND FITNESS FOR A PARTICULAR PURPOSE. THE ENTIRE RISK AS TO THE QUALITY AND PERFORMANCE OF THE PROGRAM IS WITH YOU. SHOULD THE PROGRAM PROVE DEFECTIVE, YOU ASSUME THE COST OF ALL NECESSARY SERVICING, REPAIR OR CORRECTION.

12. IN NO EVENT UNLESS REQUIRED BY APPLICABLE LAW OR AGREED TO IN WRITING WILL ANY COPYRIGHT HOLDER, OR ANY OTHER PARTY WHO MAY MODIFY AND/OR REDISTRIBUTE THE PROGRAM AS PERMITTED ABOVE, BE LIABLE TO YOU FOR DAMAGES, INCLUDING ANY GENERAL, SPECIAL, INCIDENTAL OR CONSEQUENTIAL DAMAGES ARISING OUT OF THE USE OR INABILITY TO USE THE PROGRAM (INCLUDING BUT NOT LIMITED TO LOSS OF DATA OR DATA BEING RENDERED INACCURATE OR LOSSES SUSTAINED BY YOU OR THIRD PARTIES OR A FAILURE OF THE PROGRAM TO OPERATE WITH ANY OTHER PROGRAMS), EVEN IF SUCH HOLDER OR OTHER PARTY HAS BEEN ADVISED OF THE POSSIBILITY OF SUCH DAMAGES.

## END OF TERMS AND CONDITIONS

### How to Apply These Terms to Your New Programs

If you develop a new program, and you want it to be of the greatest possible use to the public, the best way to achieve this is to make it free software which everyone can redistribute and change under these terms.

To do so, attach the following notices to the program. It is safest to attach them to the start of each source file to most effectively convey the exclusion of warranty; and each file should have at least the "copyright" line and a pointer to where the full notice is found.

One line to give the program's name and a brief idea of what it does.  
Copyright © <year> <name of author>

This program is free software; you can redistribute it and/or modify it under the terms of the GNU General Public License as published by the Free Software Foundation; either version 2 of the License, or (at your option) any later version.

This program is distributed in the hope that it will be useful, but WITHOUT ANY WARRANTY; without even the implied warranty of MERCHANTABILITY or FITNESS FOR A PARTICULAR PURPOSE. See the GNU General Public License for more details.

You should have received a copy of the GNU General Public License along with this program; if not, write to the Free Software Foundation, Inc., 59 Temple Place, Suite 330, Boston, MA 02111-1307 USA

Also add information on how to contact you by electronic and paper mail.

If the program is interactive, make it output a short notice like this when it starts in an interactive mode:

```
Gnomovision version 69, Copyright © year name of author Gnomovision comes with ABSOLUTELY NO WARRANTY; for details type `show w'. This is free software, and you are welcome to redistribute it under certain conditions; type `show c' for details.
```

The hypothetical commands `show w' and `show c' should show the appropriate parts of the General Public License. Of course, the commands you use may be called something other than `show w' and `show c'; they could even be mouse-clicks or menu items--whatever suits your program.

You should also get your employer (if you work as a programmer) or your school, if any, to sign a "copyright disclaimer" for the program, if necessary. Here is a sample; alter the names:

```
Yoyodyne, Inc., hereby disclaims all copyright interest in the program `Gnomovision' (which makes passes at compilers) written by James Hacker.
```

```
signature of Ty Coon, 1 April 1989  
Ty Coon, President of Vice
```

This General Public License does not permit incorporating your program into proprietary programs. If your program is a subroutine library, you may consider it more useful to permit linking proprietary applications with the library. If this is what you want to do, use the GNU Library General Public License instead of this License.

## GNU Lesser General Public License

Version 2.1, February 1999

Copyright © 1991, 1999 Free Software Foundation, Inc. 59 Temple Place, Suite 330, Boston, MA 02111-1307 USA Everyone is permitted to copy and distribute verbatim copies of this license document, but changing it is not allowed.

[This is the first released version of the Lesser GPL. It also counts as the successor of the GNU Library Public License, version 2, hence the version number 2.1.]

### Preamble

The licenses for most software are designed to take away your freedom to share and change it. By contrast, the GNU General Public Licenses are intended to guarantee your freedom to share and change free software--to make sure the software is free for all its users.

This license, the Lesser General Public License, applies to some specially designated software packages--typically libraries--of the Free Software Foundation and other authors who decide to use it. You can use it too, but we suggest you first think carefully about whether this license or the ordinary General Public License is the better strategy to use in any particular case, based on the explanations below.

When we speak of free software, we are referring to freedom of use, not price. Our General Public Licenses are designed to make sure that you have the freedom to distribute copies of free software (and charge for this service if you wish); that you receive source code or can get it if you want it; that you can change the software and use pieces of it in new free programs; and that you are informed that you can do these things.

To protect your rights, we need to make restrictions that forbid distributors to deny you these rights or to ask you to surrender these rights. These restrictions translate to certain responsibilities for you if you distribute copies of the library or if you modify it.

For example, if you distribute copies of the library, whether gratis or for a fee, you must give the recipients all the rights that we gave you. You must make sure that they, too, receive or can get the source code. If you link other code with the library, you must provide complete object files to the recipients, so that they can relink them with the library after making changes to the library and recompiling it. And you must show them these terms so they know their rights.

We protect your rights with a two-step method: (1) we copyright the library, and (2) we offer you this license, which gives you legal permission to copy, distribute and/or modify the library.

To protect each distributor, we want to make it very clear that there is no warranty for the free library. Also, if the library is modified by someone else and passed on, the recipients should know that what they have is not the original version, so that the original author's reputation will not be affected by problems that might be introduced by others.

Finally, software patents pose a constant threat to the existence of any free program. We wish to make sure that a company cannot effectively restrict the users of a free program by obtaining a restrictive license from a patent holder. Therefore, we insist that any patent license obtained for a version of the library must be consistent with the full freedom of use specified in this license.

Most GNU software, including some libraries, is covered by the ordinary GNU General Public License. This license, the GNU Lesser General Public License, applies to certain designated libraries, and is quite different from the ordinary General Public License. We use this license for certain libraries in order to permit linking those libraries into non-free programs.

When a program is linked with a library, whether statically or using a shared library, the combination of the two is legally speaking a combined work, a derivative of the original library. The ordinary General Public License therefore permits such linking only if the entire combination fits its criteria of freedom. The Lesser General Public License permits more lax criteria for linking other code with the library.

We call this license the "Lesser" General Public License because it does Less to protect the user's freedom than the ordinary General Public License. It also provides other free software developers Less of an advantage over competing non-free programs. These disadvantages are the reason we use the ordinary General Public License for many libraries. However, the Lesser license provides advantages in certain special circumstances.

For example, on rare occasions, there may be a special need to encourage the widest possible use of a certain library, so that it becomes a de-facto standard. To achieve this, non-free programs must be allowed to use the library. A more frequent case is that a free library does the same job as widely used non-free libraries. In this case, there is little to gain by limiting the free library to free software only, so we use the Lesser General Public License.

In other cases, permission to use a particular library in non-free programs enables a greater number of people to use a large body of free software. For example, permission to use the GNU C Library in non-free programs

---

enables many more people to use the whole GNU operating system, as well as its variant, the GNU/Linux operating system.

Although the Lesser General Public License is Less protective of the users' freedom, it does ensure that the user of a program that is linked with the Library has the freedom and the wherewithal to run that program using a modified version of the Library.

The precise terms and conditions for copying, distribution and modification follow. Pay close attention to the difference between a "work based on the library" and a "work that uses the library". The former contains code derived from the library, whereas the latter must be combined with the library in order to run.

#### TERMS AND CONDITIONS FOR COPYING, DISTRIBUTION AND MODIFICATION

0. This License Agreement applies to any software library or other program which contains a notice placed by the copyright holder or other authorized party saying it may be distributed under the terms of this Lesser General Public License (also called "this License"). Each licensee is addressed as "you".

A "library" means a collection of software functions and/or data prepared so as to be conveniently linked with application programs (which use some of those functions and data) to form executables.

The "Library", below, refers to any such software library or work which has been distributed under these terms. A "work based on the Library" means either the Library or any derivative work under copyright law: that is to say, a work containing the Library or a portion of it, either verbatim or with modifications and/or translated straightforwardly into another language. (Hereinafter, translation is included without limitation in the term "modification".)

"Source code" for a work means the preferred form of the work for making modifications to it. For a library, complete source code means all the source code for all modules it contains, plus any associated interface definition files, plus the scripts used to control compilation and installation of the library.

Activities other than copying, distribution and modification are not covered by this License; they are outside its scope. The act of running a program using the Library is not restricted, and output from such a program is covered only if its contents constitute a work based on the Library (independent of the use of the Library in a tool for writing it). Whether that is true depends on what the Library does and what the program that uses the Library does.

1. You may copy and distribute verbatim copies of the Library's complete source code as you receive it, in any medium, provided that you conspicuously and appropriately publish on each copy an appropriate copyright notice and disclaimer of warranty; keep intact all the notices that refer to this License and to the absence of any warranty; and distribute a copy of this License along with the Library.

You may charge a fee for the physical act of transferring a copy, and you may at your option offer warranty protection in exchange for a fee.

2. You may modify your copy or copies of the Library or any portion of it, thus forming a work based on the Library, and copy and distribute such modifications or work under the terms of Section 1 above, provided that you also meet all of these conditions:

a) The modified work must itself be a software library.

b) You must cause the files modified to carry prominent notices stating that you changed the files and the date of any change.

c) You must cause the whole of the work to be licensed at no charge to all third parties under the terms of this License.

d) If a facility in the modified Library refers to a function or a table of data to be supplied by an application program that uses the facility, other than as an argument passed when the facility is invoked, then you must make a good faith effort to ensure that, in the event an application does not supply such function or table, the facility still operates, and performs whatever part of its purpose remains meaningful.

(For example, a function in a library to compute square roots has a purpose that is entirely well-defined independent of the application. Therefore, Subsection 2d requires that any application-supplied function or table used by this function must be optional: if the application does not supply it, the square root function must still compute square roots.)

These requirements apply to the modified work as a whole. If identifiable sections of that work are not derived from the Library, and can be reasonably considered independent and separate works in themselves, then this License, and its terms, do not apply to those sections when you distribute them as separate works. But when you distribute the same sections as part of a whole which is a work based on the Library, the distribution of the whole must be on the terms of this License, whose permissions for other licensees extend to the entire whole, and thus to each and every part regardless of who wrote it.

Thus, it is not the intent of this section to claim rights or contest your rights to work written entirely by you; rather, the intent is to exercise the right to control the distribution of derivative or collective works based on the Library.

In addition, mere aggregation of another work not based on the Library with the Library (or with a work based on the Library) on a volume of a storage or distribution medium does not bring the other work under the scope of this License.

3. You may opt to apply the terms of the ordinary GNU General Public License instead of this License to a given copy of the Library. To do this, you must alter all the notices that refer to this License, so that they refer to the ordinary GNU General Public License, version 2, instead of to this License. (If a newer version than version 2 of the ordinary GNU General Public License has appeared, then you can specify that version instead if you wish.) Do not make any other change in these notices.

Once this change is made in a given copy, it is irreversible for that copy, so the ordinary GNU General Public License applies to all subsequent copies and derivative works made from that copy.

This option is useful when you wish to copy part of the code of the Library into a program that is not a library.

4. You may copy and distribute the Library (or a portion or derivative of it, under Section 2) in object code or executable form under the terms of Sections 1 and 2 above provided that you accompany it with the complete corresponding machine-readable source code, which must be distributed under the terms of Sections 1 and 2 above on a medium customarily used for software interchange.

If distribution of object code is made by offering access to copy from a designated place, then offering equivalent access to copy the source code from the same place satisfies the requirement to distribute the source code, even though third parties are not compelled to copy the source along with the object code.

5. A program that contains no derivative of any portion of the Library, but is designed to work with the Library by being compiled or linked with it, is called a "work that uses the Library". Such a work, in isolation, is not a derivative work of the Library, and therefore falls outside the scope of this License.

However, linking a "work that uses the Library" with the Library creates an executable that is a derivative of the Library (because it contains portions of the Library), rather than a "work that uses the library". The executable is therefore covered by this License. Section 6 states terms for distribution of such executables.

When a "work that uses the Library" uses material from a header file that is part of the Library, the object code for the work may be a derivative work of the Library even though the source code is not. Whether this is true is especially significant if the work can be linked without the Library, or if the work is itself a library. The threshold for this to be true is not precisely defined by law.

If such an object file uses only numerical parameters, data structure layouts and accessors, and small macros and small inline functions (ten lines or less in length), then the use of the object file is unrestricted, regardless of whether it is legally a derivative work. (Executables containing this object code plus portions of the Library will still fall under Section 6.)

Otherwise, if the work is a derivative of the Library, you may distribute the object code for the work under the terms of Section 6. Any executables containing that work also fall under Section 6, whether or not they are linked directly with the Library itself.

6. As an exception to the Sections above, you may also combine or link a "work that uses the Library" with the Library to produce a work containing portions of the Library, and distribute that work under terms of your choice, provided that the terms permit modification of the work for the customer's own use and reverse engineering for debugging such modifications.

You must give prominent notice with each copy of the work that the Library is used in it and that the Library and its use are covered by this License. You must supply a copy of this License. If the work during execution displays copyright notices, you must include the copyright notice for the Library among them, as well as a reference directing the user to the copy of this License. Also, you must do one of these things:

a) Accompany the work with the complete corresponding machine-readable source code for the Library including whatever changes were used in the work (which must be distributed under Sections 1 and 2 above); and, if the work is an executable linked with the Library, with the complete machine-readable "work that uses the Library", as object code and/or source code, so that the user can modify the Library and then relink to produce a modified executable containing the modified Library. (It is understood that the user who changes the contents of definitions files in the Library will not necessarily be able to recompile the application to use the modified definitions.)

b) Use a suitable shared library mechanism for linking with the Library. A suitable mechanism is one that (1) uses at run time a copy of the library already present on the user's computer system, rather than copying library functions into the executable, and (2) will operate properly with a modified version of the library, if the user installs one, as long as the modified version is interface-compatible with the version that the work was made with.

- 
- c) Accompany the work with a written offer, valid for at least three years, to give the same user the materials specified in Subsection 6a, above, for a charge no more than the cost of performing this distribution.
- d) If distribution of the work is made by offering access to copy from a designated place, offer equivalent access to copy the above specified materials from the same place.
- e) Verify that the user has already received a copy of these materials or that you have already sent this user a copy.

For an executable, the required form of the "work that uses the Library" must include any data and utility programs needed for reproducing the executable from it. However, as a special exception, the materials to be distributed need not include anything that is normally distributed (in either source or binary form) with the major components (compiler, kernel, and so on) of the operating system on which the executable runs, unless that component itself accompanies the executable.

It may happen that this requirement contradicts the license restrictions of other proprietary libraries that do not normally accompany the operating system. Such a contradiction means you cannot use both them and the Library together in an executable that you distribute.

7. You may place library facilities that are a work based on the Library side-by-side in a single library together with other library facilities not covered by this License, and distribute such a combined library, provided that the separate distribution of the work based on the Library and of the other library facilities is otherwise permitted, and provided that you do these two things:

- a) Accompany the combined library with a copy of the same work based on the Library, uncombined with any other library facilities. This must be distributed under the terms of the Sections above.
- b) Give prominent notice with the combined library of the fact that part of it is a work based on the Library, and explaining where to find the accompanying uncombined form of the same work.

8. You may not copy, modify, sublicense, link with, or distribute the Library except as expressly provided under this License. Any attempt otherwise to copy, modify, sublicense, link with, or distribute the Library is void, and will automatically terminate your rights under this License. However, parties who have received copies, or rights, from you under this License will not have their licenses terminated so long as such parties remain in full compliance.

9. You are not required to accept this License, since you have not signed it. However, nothing else grants you permission to modify or distribute the Library or its derivative works. These actions are prohibited by law if you do not accept this License. Therefore, by modifying or distributing the Library (or any work based on the Library), you indicate your acceptance of this License to do so, and all its terms and conditions for copying, distributing or modifying the Library or works based on it.

10. Each time you redistribute the Library (or any work based on the Library), the recipient automatically receives a license from the original licensor to copy, distribute, link with or modify the Library subject to these terms and conditions. You may not impose any further restrictions on the recipients' exercise of the rights granted herein. You are not responsible for enforcing compliance by third parties with this License.

11. If, as a consequence of a court judgment or allegation of patent infringement or for any other reason (not limited to patent issues), conditions are imposed on you (whether by court order, agreement or otherwise) that contradict the conditions of this License, they do not excuse you from the conditions of this License. If you cannot distribute so as to satisfy simultaneously your obligations under this License and any other pertinent obligations, then as a consequence you may not distribute the Library at all. For example, if a patent license would not permit royalty-free redistribution of the Library by all those who receive copies directly or indirectly through you, then the only way you could satisfy both it and this License would be to refrain entirely from distribution of the Library.

If any portion of this section is held invalid or unenforceable under any particular circumstance, the balance of the section is intended to apply, and the section as a whole is intended to apply in other circumstances.

It is not the purpose of this section to induce you to infringe any patents or other property right claims or to contest validity of any such claims; this section has the sole purpose of protecting the integrity of the free software distribution system which is implemented by public license practices. Many people have made generous contributions to the wide range of software distributed through that system in reliance on consistent application of that system; it is up to the author/donor to decide if he or she is willing to distribute software through any other system and a licensee cannot impose that choice.

This section is intended to make thoroughly clear what is believed to be a consequence of the rest of this License.

12. If the distribution and/or use of the Library is restricted in certain countries either by patents or by copyrighted interfaces, the original copyright holder who places the Library under this License may add an explicit geographical distribution limitation excluding those countries, so that distribution is permitted only in or among countries not thus excluded. In such case, this License incorporates the limitation as if written in the body of this License.

13. The Free Software Foundation may publish revised and/or new versions of the Lesser General Public License from time to time. Such new versions will be similar in spirit to the present version, but may differ in detail to address new problems or concerns.

Each version is given a distinguishing version number. If the Library specifies a version number of this License which applies to it and "any later version", you have the option of following the terms and conditions either of that version or of any later version published by the Free Software Foundation. If the Library does not specify a license version number, you may choose any version ever published by the Free Software Foundation.

14. If you wish to incorporate parts of the Library into other free programs whose distribution conditions are incompatible with these, write to the author to ask for permission. For software which is copyrighted by the Free Software Foundation, write to the Free Software Foundation; we sometimes make exceptions for this. Our decision will be guided by the two goals of preserving the free status of all derivatives of our free software and of promoting the sharing and reuse of software generally.

#### NO WARRANTY

15. BECAUSE THE LIBRARY IS LICENSED FREE OF CHARGE, THERE IS NO WARRANTY FOR THE LIBRARY, TO THE EXTENT PERMITTED BY APPLICABLE LAW. EXCEPT WHEN OTHERWISE STATED IN WRITING THE COPYRIGHT HOLDERS AND/OR OTHER PARTIES PROVIDE THE LIBRARY "AS IS" WITHOUT WARRANTY OF ANY KIND, EITHER EXPRESSED OR IMPLIED, INCLUDING, BUT NOT LIMITED TO, THE IMPLIED WARRANTIES OF MERCHANTABILITY AND FITNESS FOR A PARTICULAR PURPOSE. THE ENTIRE RISK AS TO THE QUALITY AND PERFORMANCE OF THE LIBRARY IS WITH YOU. SHOULD THE LIBRARY PROVE DEFECTIVE, YOU ASSUME THE COST OF ALL NECESSARY SERVICING, REPAIR OR CORRECTION.

16. IN NO EVENT UNLESS REQUIRED BY APPLICABLE LAW OR AGREED TO IN WRITING WILL ANY COPYRIGHT HOLDER, OR ANY OTHER PARTY WHO MAY MODIFY AND/OR REDISTRIBUTE THE LIBRARY AS PERMITTED ABOVE, BE LIABLE TO YOU FOR DAMAGES, INCLUDING ANY GENERAL, SPECIAL, INCIDENTAL OR CONSEQUENTIAL DAMAGES ARISING OUT OF THE USE OR INABILITY TO USE THE LIBRARY (INCLUDING BUT NOT LIMITED TO LOSS OF DATA OR DATA BEING RENDERED INACCURATE OR LOSSES SUSTAINED BY YOU OR THIRD PARTIES OR A FAILURE OF THE LIBRARY TO OPERATE WITH ANY OTHER SOFTWARE), EVEN IF SUCH HOLDER OR OTHER PARTY HAS BEEN ADVISED OF THE POSSIBILITY OF SUCH DAMAGES.

#### END OF TERMS AND CONDITIONS

##### How to Apply These Terms to Your New Libraries

If you develop a new library, and you want it to be of the greatest possible use to the public, we recommend making it free software that everyone can redistribute and change. You can do so by permitting redistribution under these terms (or, alternatively, under the terms of the ordinary General Public License).

To apply these terms, attach the following notices to the library. It is safest to attach them to the start of each source file to most effectively convey the exclusion of warranty; and each file should have at least the "copyright" line and a pointer to where the full notice is found.

<one line to give the library's name and an idea of what it does.> Copyright © <year> <name of author>

This library is free software; you can redistribute it and/or modify it under the terms of the GNU Lesser General Public License as published by the Free Software Foundation; either version 2.1 of the License, or (at your option) any later version.

This library is distributed in the hope that it will be useful, but WITHOUT ANY WARRANTY; without even the implied warranty of MERCHANTABILITY or FITNESS FOR A PARTICULAR PURPOSE. See the GNU Lesser General Public License for more details.

You should have received a copy of the GNU Lesser General Public License along with this library; if not, write to the Free Software Foundation, Inc., 59 Temple Place, Suite 330, Boston, MA 02111-1307 USA

Also add information on how to contact you by electronic and paper mail.

You should also get your employer (if you work as a programmer) or your school, if any, to sign a "copyright disclaimer" for the library, if necessary. Here is a sample; alter the names:

Yoyodyne, Inc., hereby disclaims all copyright interest in the library `Frob' (a library for tweaking knobs) written by James Random Hacker.

signature of Ty Coon, 1 April 1990

Ty Coon, President of Vice

That's all there is to it!

---

## APPLE PUBLIC SOURCE LICENSE

Version 2.0 - August 6, 2003

Please read this License carefully before downloading this software.

By downloading or using this software, you are agreeing to be bound by the terms of this License. If you do not or cannot agree to the terms of this License, please do not download or use the software.

1. General; Definitions. This License applies to any program or other work which Apple Computer, Inc. ("Apple") makes publicly available and which contains a notice placed by Apple identifying such program or work as "Original Code" and stating that it is subject to the terms of this Apple Public Source License version 2.0 ("License"). As used in this License:

1.1 "Applicable Patent Rights" mean: (a) in the case where Apple is the grantor of rights, (i) claims of patents that are now or hereafter acquired, owned by or assigned to Apple and (ii) that cover subject matter contained in the Original Code, but only to the extent necessary to use, reproduce and/or distribute the Original Code without infringement; and (b) in the case where You are the grantor of rights, (i) claims of patents that are now or hereafter acquired, owned by or assigned to You and (ii) that cover subject matter in Your Modifications, taken alone or in combination with Original Code.

1.2 "Contributor" means any person or entity that creates or contributes to the creation of Modifications.

1.3 "Covered Code" means the Original Code, Modifications, the combination of Original Code and any Modifications, and/or any respective portions thereof.

1.4 "Externally Deploy" mean: (a) to sublicense, distribute or otherwise make Covered Code available, directly or indirectly, to anyone other than You; and/or (b) to use Covered Code, alone or as part of a Larger Work, in any way to provide a service, including but not limited to delivery of content, through electronic communication with a client other than You.

1.5 "Larger Work" means a work which combines Covered Code or portions thereof with code not governed by the terms of this License.

1.6 "Modifications" mean any addition to, deletion from, and/or change to, the substance and/or structure of the Original Code, any previous Modifications, the combination of Original Code and any previous Modifications, and/or any respective portions thereof. When code is released as a series of files, a Modification is: (a) any addition to or deletion from the contents of a file containing Covered Code; and/or (b) any new file or other representation of computer program statements that contains any part of Covered Code.

1.7 "Original Code" means (a) the Source Code of a program or other work as originally made available by Apple under this License, including the Source Code of any updates or upgrades to such programs or works made available by Apple under this License, and that has been expressly identified by Apple as such in the header file(s) of such work; and (b) the object code compiled from such Source Code and originally made available by Apple under this License.

1.8 "Source Code" means the human readable form of a program or other work that is suitable for making modifications to it, including all modules it contains, plus any associated interface definition files, scripts used to control compilation and installation of an executable (object code).

1.9 "You" or "Your" means an individual or a legal entity exercising rights under this License. For legal entities, "You" or "Your" includes any entity which controls, is controlled by, or is under common control with, You, where "control" means (a) the power, direct or indirect, to cause the direction or management of such entity, whether by contract or otherwise, or (b) ownership of fifty percent (50%) or more of the outstanding shares or beneficial ownership of such entity.

2. Permitted Uses; Conditions & Restrictions. Subject to the terms and conditions of this License, Apple hereby grants You, effective on the date You accept this License and download the Original Code, a world-wide, royalty-free, non-exclusive license, to the extent of Apple's Applicable Patent Rights and copyrights covering the Original Code, to do the following:

2.1 Unmodified Code. You may use, reproduce, display, perform, internally distribute within Your organization, and Externally Deploy verbatim, unmodified copies of the Original Code, for commercial or non-commercial purposes, provided that in each instance:

(a) You must retain and reproduce in all copies of Original Code the copyright and other proprietary notices and disclaimers of Apple as they appear in the Original Code, and keep intact all notices in the Original Code that refer to this License; and

(b) You must include a copy of this License with every copy of Source Code of Covered Code and documentation You distribute or Externally Deploy, and You may not offer or impose any terms on such Source Code that alter or restrict this License or the recipients' rights hereunder, except as permitted under Section 6.

2.2 Modified Code. You may modify Covered Code and use, reproduce, display, perform, internally distribute within Your organization, and Externally Deploy Your Modifications and Covered Code, for commercial or non-commercial purposes, provided that in each instance You also meet all of these conditions:

(a) You must satisfy all the conditions of Section 2.1 with respect to the Source Code of the Covered Code;

(b) You must duplicate, to the extent it does not already exist, the notice in Exhibit A in each file of the Source Code of all Your Modifications, and cause the modified files to carry prominent notices stating that You changed the files and the date of any change; and

(c) If You Externally Deploy Your Modifications, You must make Source Code of all Your Externally Deployed Modifications either available to those to whom You have Externally Deployed Your Modifications, or publicly available. Source Code of Your Externally Deployed Modifications must be released under the terms set forth in this License, including the license grants set forth in Section 3 below, for as long as you Externally Deploy the Covered Code or twelve (12) months from the date of initial External Deployment, whichever is longer. You should preferably distribute the Source Code of Your Externally Deployed Modifications electronically (e.g. download from a web site).

2.3 Distribution of Executable Versions. In addition, if You Externally Deploy Covered Code (Original Code and/or Modifications) in object code, executable form only, You must include a prominent notice, in the code itself as well as in related documentation, stating that Source Code of the Covered Code is available under the terms of this License with information on how and where to obtain such Source Code.

2.4 Third Party Rights. You expressly acknowledge and agree that although Apple and each Contributor grants the licenses to their respective portions of the Covered Code set forth herein, no assurances are provided by Apple or any Contributor that the Covered Code does not infringe the patent or other intellectual property rights of any other entity. Apple and each Contributor disclaim any liability to You for claims brought by any other entity based on infringement of intellectual property rights or otherwise. As a condition to exercising the rights and licenses granted hereunder, You hereby assume sole responsibility to secure any other intellectual property rights needed, if any. For example, if a third party patent license is required to allow You to distribute the Covered Code, it is Your responsibility to acquire that license before distributing the Covered Code.

3. Your Grants. In consideration of, and as a condition to, the licenses granted to You under this License, You hereby grant to any person or entity receiving or distributing Covered Code under this License a non-exclusive, royalty-free, perpetual, irrevocable license, under Your Applicable Patent Rights and other intellectual property rights (other than patent) owned or controlled by You, to use, reproduce, display, perform, modify, sublicense, distribute and Externally Deploy Your Modifications of the same scope and extent as Apple's licenses under Sections 2.1 and 2.2 above.

4. Larger Works. You may create a Larger Work by combining Covered Code with other code not governed by the terms of this License and distribute the Larger Work as a single product. In each such instance, You must make sure the requirements of this License are fulfilled for the Covered Code or any portion thereof.

5. Limitations on Patent License. Except as expressly stated in Section 2, no other patent rights, express or implied, are granted by Apple herein. Modifications and/or Larger Works may require additional patent licenses from Apple which Apple may grant in its sole discretion.

6. Additional Terms. You may choose to offer, and to charge a fee for, warranty, support, indemnity or liability obligations and/or other rights consistent with the scope of the license granted herein ("Additional Terms") to one or more recipients of Covered Code.

However, You may do so only on Your own behalf and as Your sole responsibility, and not on behalf of Apple or any Contributor. You must obtain the recipient's agreement that any such Additional Terms are offered by You alone, and You hereby agree to indemnify, defend and hold Apple and every Contributor harmless for any liability incurred by or claims asserted against Apple or such Contributor by reason of any such Additional Terms.

7. Versions of the License. Apple may publish revised and/or new versions of this License from time to time. Each version will be given a distinguishing version number. Once Original Code has been published under a particular version of this License, You may continue to use it under the terms of that version. You may also choose to use such Original Code under the terms of any subsequent version of this License published by Apple. No one other than Apple has the right to modify the terms applicable to Covered Code created under this License.

8. NO WARRANTY OR SUPPORT. The Covered Code may contain in whole or in part pre-release, untested, or not fully tested works. The Covered Code may contain errors that could cause failures or loss of data, and may be incomplete or contain inaccuracies. You expressly acknowledge and agree that use of the Covered Code, or any portion thereof, is at Your sole and entire risk. THE COVERED CODE IS PROVIDED "AS IS" AND WITHOUT WARRANTY, UPGRADES OR SUPPORT OF ANY KIND AND APPLE AND APPLE'S LICENSOR(S) (COLLECTIVELY REFERRED TO AS "APPLE" FOR THE PURPOSES OF SECTIONS 8 AND 9) AND ALL CONTRIBUTORS EXPRESSLY DISCLAIM ALL WARRANTIES AND/OR CONDITIONS, EXPRESS OR IMPLIED, INCLUDING, BUT NOT LIMITED TO, THE IMPLIED WARRANTIES AND/OR CONDITIONS OF



MERCHANTABILITY, OF SATISFACTORY QUALITY, OF FITNESS FOR A PARTICULAR PURPOSE, OF ACCURACY, OF QUIET ENJOYMENT, AND NONINFRINGEMENT OF THIRD PARTY RIGHTS. APPLE AND EACH CONTRIBUTOR DOES NOT WARRANT AGAINST INTERFERENCE WITH YOUR ENJOYMENT OF THE COVERED CODE, THAT THE FUNCTIONS CONTAINED IN THE COVERED CODE WILL MEET YOUR REQUIREMENTS, THAT THE OPERATION OF THE COVERED CODE WILL BE UNINTERRUPTED OR ERROR-FREE, OR THAT DEFECTS IN THE COVERED CODE WILL BE CORRECTED. NO ORAL OR WRITTEN INFORMATION OR ADVICE GIVEN BY APPLE, AN APPLE AUTHORIZED REPRESENTATIVE OR ANY CONTRIBUTOR SHALL CREATE A WARRANTY.

You acknowledge that the Covered Code is not intended for use in the operation of nuclear facilities, aircraft navigation, communication systems, or air traffic control machines in which case the failure of the Covered Code could lead to death, personal injury, or severe physical or environmental damage.

9. LIMITATION OF LIABILITY. TO THE EXTENT NOT PROHIBITED BY LAW, IN NO EVENT SHALL APPLE OR ANY CONTRIBUTOR BE LIABLE FOR ANY INCIDENTAL, SPECIAL, INDIRECT OR CONSEQUENTIAL DAMAGES ARISING OUT OF OR RELATING TO THIS LICENSE OR YOUR USE OR INABILITY TO USE THE COVERED CODE, OR ANY PORTION THEREOF, WHETHER UNDER A THEORY OF CONTRACT, WARRANTY, TORT (INCLUDING NEGLIGENCE), PRODUCTS LIABILITY OR OTHERWISE, EVEN IF APPLE OR SUCH CONTRIBUTOR HAS BEEN ADVISED OF THE POSSIBILITY OF SUCH DAMAGES AND NOTWITHSTANDING THE FAILURE OF ESSENTIAL PURPOSE OF ANY REMEDY. SOME JURISDICTIONS DO NOT ALLOW THE LIMITATION OF LIABILITY OF INCIDENTAL OR CONSEQUENTIAL DAMAGES, SO THIS LIMITATION MAY NOT APPLY TO YOU. In no event shall Apple's total liability to You for all damages (other than as may be required by applicable law) under this License exceed the amount of fifty dollars (\$50.00).

10. Trademarks. This License does not grant any rights to use the trademarks or trade names "Apple", "Apple Computer", "Mac", "Mac OS", "QuickTime", "QuickTime Streaming Server" or any other trademarks, service marks, logos or trade names belonging to Apple (collectively "Apple Marks") or to any trademark, service mark, logo or trade name belonging to any Contributor. You agree not to use any Apple Marks in or as part of the name of products derived from the Original Code or to endorse or promote products derived from the Original Code other than as expressly permitted by and in strict compliance at all times with Apple's third party trademark usage guidelines which are posted at <http://www.apple.com/legal/guidelinesfor3rdparties.html>.

11. Ownership. Subject to the licenses granted under this License, each Contributor retains all rights, title and interest in and to any Modifications made by such Contributor. Apple retains all rights, title and interest in and to the Original Code and any Modifications made by or on behalf of Apple ("Apple Modifications"), and such Apple Modifications will not be automatically subject to this License. Apple may, at its sole discretion, choose to license such Apple Modifications under this License, or on different terms from those contained in this License or may choose not to license them at all.

12. Termination.

12.1 Termination. This License and the rights granted hereunder will terminate:

(a) automatically without notice from Apple if You fail to comply with any term(s) of this License and fail to cure such breach within 30 days of becoming aware of such breach;

(b) immediately in the event of the circumstances described in Section 13.5(b); or

(c) automatically without notice from Apple if You, at any time during the term of this License, commence an action for patent infringement against Apple; provided that Apple did not first commence an action for patent infringement against You in that instance.

12.2 Effect of Termination. Upon termination, You agree to immediately stop any further use, reproduction, modification, sublicensing and distribution of the Covered Code. All sublicenses to the Covered Code which have been properly granted prior to termination shall survive any termination of this License. Provisions which, by their nature, should remain in effect beyond the termination of this License shall survive, including but not limited to Sections 3, 5, 8, 9, 10, 11, 12.2 and 13. No party will be liable to any other for compensation, indemnity or damages of any sort solely as a result of terminating this License in accordance with its terms, and termination of this License will be without prejudice to any other right or remedy of any party.

13. Miscellaneous.

13.1 Government End Users. The Covered Code is a "commercial item" as defined in FAR 2.101. Government software and technical data rights in the Covered Code include only those rights customarily provided to the public as defined in this License. This customary commercial license in technical data and software is provided in accordance with FAR 12.211 (Technical Data) and 12.212 (Computer Software) and, for Department of Defense purchases, DFAR 252.227-7015 (Technical Data -- Commercial Items) and 227.7202-3 (Rights in Commercial Computer Software or Computer Software Documentation). Accordingly, all U.S. Government End Users acquire Covered Code with only those rights set forth herein.

13.2 Relationship of Parties. This License will not be construed as creating an agency, partnership, joint venture or any other form of legal association between or among You, Apple or any Contributor, and You will not represent to the contrary, whether expressly, by implication, appearance or otherwise.

13.3 Independent Development. Nothing in this License will impair Apple's right to acquire, license, develop, have others develop for it, market and/or distribute technology or products that perform the same or similar functions as, or otherwise compete with, Modifications, Larger Works, technology or products that You may develop, produce, market or distribute.

13.4 Waiver; Construction. Failure by Apple or any Contributor to enforce any provision of this License will not be deemed a waiver of future enforcement of that or any other provision. Any law or regulation which provides that the language of a contract shall be construed against the drafter will not apply to this License.

13.5 Severability. (a) If for any reason a court of competent jurisdiction finds any provision of this License, or portion thereof, to be unenforceable, that provision of the License will be enforced to the maximum extent permissible so as to effect the economic benefits and intent of the parties, and the remainder of this License will continue in full force and effect. (b) Notwithstanding the foregoing, if applicable law prohibits or restricts You from fully and/or specifically complying with Sections 2 and/or 3 or prevents the enforceability of either of those Sections, this License will immediately terminate and You must immediately discontinue any use of the Covered Code and destroy all copies of it that are in your possession or control.

13.6 Dispute Resolution. Any litigation or other dispute resolution between You and Apple relating to this License shall take place in the Northern District of California, and You and Apple hereby consent to the personal jurisdiction of, and venue in, the state and federal courts within that District with respect to this License. The application of the United Nations Convention on Contracts for the International Sale of Goods is expressly excluded.

13.7 Entire Agreement; Governing Law. This License constitutes the entire agreement between the parties with respect to the subject matter hereof. This License shall be governed by the laws of the United States and the State of California, except that body of California law concerning conflicts of law.

Where You are located in the province of Quebec, Canada, the following clause applies: The parties hereby confirm that they have requested that this License and all related documents be drafted in English. Les parties ont exigé que le présent contrat et tous les documents connexes soient rédigés en anglais.

EXHIBIT A.

"Portions Copyright © 1999-2003 Apple Computer, Inc. All Rights Reserved.

This file contains Original Code and/or Modifications of Original Code as defined in and that are subject to the Apple Public Source License Version 2.0 (the 'License'). You may not use this file except in compliance with the License. Please obtain a copy of the License at <http://www.opensource.apple.com/apsl/> and read it before using this file.

The Original Code and all software distributed under the License are distributed on an 'AS IS' basis, WITHOUT WARRANTY OF ANY KIND, EITHER EXPRESS OR IMPLIED, AND APPLE HEREBY DISCLAIMS ALL SUCH WARRANTIES, INCLUDING WITHOUT LIMITATION, ANY WARRANTIES OF MERCHANTABILITY, FITNESS FOR A PARTICULAR PURPOSE, QUIET ENJOYMENT OR NON-INFRINGEMENT.

Please see the License for the specific language governing rights and limitations under the License."

## **Apache License, Version 2.0**

Apache License

Version 2.0, January 2004

<http://www.apache.org/licenses/>

### **TERMS AND CONDITIONS FOR USE, REPRODUCTION, AND DISTRIBUTION**

#### **1. Definitions.**

"License" shall mean the terms and conditions for use, reproduction, and distribution as defined by Sections 1 through 9 of this document.

"Licensor" shall mean the copyright owner or entity authorized by the copyright owner that is granting the License.

"Legal Entity" shall mean the union of the acting entity and all other entities that control, are controlled by, or are under common control with that entity. For the purposes of this definition, "control" means (i) the power, direct or indirect, to cause the direction or management of such entity, whether by contract or otherwise, or (ii) ownership of fifty percent (50%) or more of the outstanding shares, or (iii) beneficial ownership of such entity.

"You" (or "Your") shall mean an individual or Legal Entity exercising permissions granted by this License.

"Source" form shall mean the preferred form for making modifications, including but not limited to software source code, documentation source, and configuration files.

"Object" form shall mean any form resulting from mechanical transformation or translation of a Source form, including but not limited to compiled object code, generated documentation, and conversions to other media types.

"Work" shall mean the work of authorship, whether in Source or Object form, made available under the License, as indicated by a copyright notice that is included in or attached to the work (an example is provided in the Appendix below).

"Derivative Works" shall mean any work, whether in Source or Object form, that is based on (or derived from) the Work and for which the editorial revisions, annotations, elaborations, or other modifications represent, as a whole, an original work of authorship. For the purposes of this License, Derivative Works shall not include works that remain separable from, or merely link (or bind by name) to the interfaces of, the Work and Derivative Works thereof.

"Contribution" shall mean any work of authorship, including the original version of the Work and any modifications or additions to that Work or Derivative Works thereof, that is intentionally submitted to Licensor for inclusion in the Work by the copyright owner or by an individual or Legal Entity authorized to submit on behalf of the copyright owner. For the purposes of this definition, "submitted" means any form of electronic, verbal, or written communication sent to the Licensor or its representatives, including but not limited to communication on electronic mailing lists, source code control systems, and issue tracking systems that are managed by, or on behalf of, the Licensor for the purpose of discussing and improving the Work, but excluding communication that is conspicuously marked or otherwise designated in writing by the copyright owner as "Not a Contribution".

"Contributor" shall mean Licensor and any individual or Legal Entity on behalf of whom a Contribution has been received by Licensor and subsequently incorporated within the Work.

## 2. Grant of Copyright License.

Subject to the terms and conditions of this License, each Contributor hereby grants to You a perpetual, worldwide, non-exclusive, no-charge, royalty-free, irrevocable copyright license to reproduce, prepare Derivative Works of, publicly display, publicly perform, sublicense, and distribute the Work and such Derivative Works in Source or Object form.

## 3. Grant of Patent License.

Subject to the terms and conditions of this License, each Contributor hereby grants to You a perpetual, worldwide, non-exclusive, no-charge, royalty-free, irrevocable (except as stated in this section) patent license to make, have made, use, offer to sell, sell, import, and otherwise transfer the Work, where such license applies only to those patent claims licensable by such Contributor that are necessarily infringed by their Contribution(s) alone or by combination of their Contribution(s) with the Work to which such Contribution(s) was submitted. If You institute patent litigation against any entity (including a cross-claim or counterclaim in a lawsuit) alleging that the Work or a Contribution incorporated within the Work constitutes direct or contributory patent infringement, then any patent licenses granted to You under this License for that Work shall terminate as of the date such litigation is filed.

## 4. Redistribution.

You may reproduce and distribute copies of the Work or Derivative Works thereof in any medium, with or without modifications, and in Source or Object form, provided that You meet the following conditions:

1. You must give any other recipients of the Work or Derivative Works a copy of this License; and
2. You must cause any modified files to carry prominent notices stating that You changed the files; and
3. You must retain, in the Source form of any Derivative Works that You distribute, all copyright, patent, trademark, and attribution notices from the Source form of the Work, excluding those notices that do not pertain to any part of the Derivative Works; and
4. If the Work includes a "NOTICE" text file as part of its distribution, then any Derivative Works that You distribute must include a readable copy of the attribution notices contained within such NOTICE file, excluding those notices that do not pertain to any part of the Derivative Works, in at least one of the following places: within a NOTICE text file distributed as part of the Derivative Works; within the Source form or documentation, if provided along with the Derivative Works; or, within a display generated by the Derivative Works, if and wherever such third-party notices normally appear. The contents of the NOTICE file are for informational purposes only and do not modify the License. You may add Your own attribution notices within Derivative Works that You distribute, alongside or as an addendum to the NOTICE text from the Work, provided that such additional attribution notices cannot be construed as modifying the License.

You may add Your own copyright statement to Your modifications and may provide additional or different license terms and conditions for use, reproduction, or distribution of Your modifications, or for any such

Derivative Works as a whole, provided Your use, reproduction, and distribution of the Work otherwise complies with the conditions stated in this License.

#### 5. Submission of Contributions.

Unless You explicitly state otherwise, any Contribution intentionally submitted for inclusion in the Work by You to the Licensor shall be under the terms and conditions of this License, without any additional terms or conditions. Notwithstanding the above, nothing herein shall supersede or modify the terms of any separate license agreement you may have executed with Licensor regarding such Contributions.

#### 6. Trademarks.

This License does not grant permission to use the trade names, trademarks, service marks, or product names of the Licensor, except as required for reasonable and customary use in describing the origin of the Work and reproducing the content of the NOTICE file.

#### 7. Disclaimer of Warranty.

Unless required by applicable law or agreed to in writing, Licensor provides the Work (and each Contributor provides its Contributions) on an "AS IS" BASIS, WITHOUT WARRANTIES OR CONDITIONS OF ANY KIND, either express or implied, including, without limitation, any warranties or conditions of TITLE, NON-INFRINGEMENT, MERCHANTABILITY, or FITNESS FOR A PARTICULAR PURPOSE. You are solely responsible for determining the appropriateness of using or redistributing the Work and assume any risks associated with Your exercise of permissions under this License.

#### 8. Limitation of Liability.

In no event and under no legal theory, whether in tort (including negligence), contract, or otherwise, unless required by applicable law (such as deliberate and grossly negligent acts) or agreed to in writing, shall any Contributor be liable to You for damages, including any direct, indirect, special, incidental, or consequential damages of any character arising as a result of this License or out of the use or inability to use the Work (including but not limited to damages for loss of goodwill, work stoppage, computer failure or malfunction, or any and all other commercial damages or losses), even if such Contributor has been advised of the possibility of such damages.

#### 9. Accepting Warranty or Additional Liability.

While redistributing the Work or Derivative Works thereof, You may choose to offer, and charge a fee for, acceptance of support, warranty, indemnity, or other liability obligations and/or rights consistent with this License. However, in accepting such obligations, You may act only on Your own behalf and on Your sole responsibility, not on behalf of any other Contributor, and only if You agree to indemnify, defend, and hold each Contributor harmless for any liability incurred by, or claims asserted against, such Contributor by reason of your accepting any such warranty or additional liability.

END OF TERMS AND CONDITIONS

APPENDIX: How to apply the Apache License to your work

To apply the Apache License to your work, attach the following boilerplate notice, with the fields enclosed by brackets "[ ]" replaced with your own identifying information. (Don't include the brackets!) The text should be enclosed in the appropriate comment syntax for the file format. We also recommend that a file or class name and description of purpose be included on the same "printed page" as the copyright notice for easier identification within third-party archives.

Copyright [yyyy] [name of copyright owner]

Licensed under the Apache License, Version 2.0 (the "License"); you may not use this file except in compliance with the License.

You may obtain a copy of the License at  
<http://www.apache.org/licenses/LICENSE-2.0>

Unless required by applicable law or agreed to in writing, software distributed under the License is distributed on an "AS IS" BASIS, WITHOUT WARRANTIES OR CONDITIONS OF ANY KIND, either express or implied. See the License for the specific language governing permissions and limitations under the License.

#### **krb5-Libs License**

Copyright © 1985-2005 by the Massachusetts Institute of Technology.

All rights reserved.

Export of this software from the United States of America may require a specific license from the United States Government. It is the responsibility of any person or organization contemplating export to obtain such a license before exporting.

---

WITHIN THAT CONSTRAINT, permission to use, copy, modify, and distribute this software and its documentation for any purpose and without fee is hereby granted, provided that the above copyright notice appear in all copies and that both that copyright notice and this permission notice appear in supporting documentation, and that the name of M.I.T. not be used in advertising or publicity pertaining to distribution of the software without specific, written prior permission. Furthermore if you modify this software you must label your software as modified software and not distribute it in such a fashion that it might be confused with the original MIT software. M.I.T. makes no representations about the suitability of this software for any purpose. It is provided "as is" without express or implied warranty.

THIS SOFTWARE IS PROVIDED "AS IS" AND WITHOUT ANY EXPRESS OR IMPLIED WARRANTIES, INCLUDING, WITHOUT LIMITATION, THE IMPLIED WARRANTIES OF MERCHANTABILITY AND FITNESS FOR A PARTICULAR PURPOSE.

Individual source code files are copyright MIT, Cygnus Support, OpenVision, Oracle, Sun Soft, FundsXpress, and others.

Project Athena, Athena, Athena MUSE, Discuss, Hesiod, Kerberos, Moira, and Zephyr are trademarks of the Massachusetts Institute of Technology (MIT). No commercial use of these trademarks may be made without prior written permission of MIT.

Commercial use means use of a name in a product or other for-profit manner. It does NOT prevent a commercial firm from referring to the MIT trademarks in order to convey information (although in doing so, recognition of their trademark status should be given).

The following copyright and permission notice applies to the OpenVision Kerberos Administration system located in kadmin/create, kadmin/dbutil, kadmin/passwd, kadmin/server, lib/kadm5, and portions of lib/rpc:

Copyright, OpenVision Technologies, Inc., 1996, All Rights Reserved

WARNING: Retrieving the OpenVision Kerberos Administration system source code, as described below, indicates your acceptance of the following terms. If you do not agree to the following terms, do not retrieve the OpenVision Kerberos administration system.

You may freely use and distribute the Source Code and Object Code compiled from it, with or without modification, but this Source Code is provided to you "AS IS" EXCLUSIVE OF ANY WARRANTY, INCLUDING, WITHOUT LIMITATION, ANY WARRANTIES OF MERCHANTABILITY OR FITNESS FOR A PARTICULAR PURPOSE, OR ANY OTHER WARRANTY, WHETHER EXPRESS OR IMPLIED. IN NO EVENT WILL OPENVISION HAVE ANY LIABILITY FOR ANY LOST PROFITS, LOSS OF DATA OR COSTS OF PROCUREMENT OF SUBSTITUTE GOODS OR SERVICES, OR FOR ANY SPECIAL, INDIRECT, OR CONSEQUENTIAL DAMAGES ARISING OUT OF THIS AGREEMENT, INCLUDING, WITHOUT LIMITATION, THOSE RESULTING FROM THE USE OF THE SOURCE CODE, OR THE FAILURE OF THE SOURCE CODE TO PERFORM, OR FOR ANY OTHER REASON.

OpenVision retains all copyrights in the donated Source Code. OpenVision also retains copyright to derivative works of the Source Code, whether created by OpenVision or by a third party. The OpenVision copyright notice must be preserved if derivative works are made based on the donated Source Code.

OpenVision Technologies, Inc. has donated this Kerberos Administration system to MIT for inclusion in the standard Kerberos 5 distribution. This donation underscores our commitment to continuing Kerberos technology development and our gratitude for the valuable work which has been performed by MIT and the Kerberos community.

Portions contributed by Matt Crawford <crawdada@fnal.gov> were work performed at Fermi National Accelerator Laboratory, which is operated by Universities Research Association, Inc., under contract DE-AC02-76CHO3000 with the U.S. Department of Energy.

The implementation of The Yarrow pseudo-random number generator in src/lib/crypto/yarrow has the following copyright:

Copyright 2000 by Zero-Knowledge Systems, Inc.

Permission to use, copy, modify, distribute, and sell this software and its documentation for any purpose is hereby granted without fee, provided that the above copyright notice appear in all copies and that both that copyright notice and this permission notice appear in supporting documentation, and that the name of Zero-Knowledge Systems, Inc. not be used in advertising or publicity pertaining to distribution of the software without specific, written prior permission. Zero-Knowledge Systems, Inc. makes no representations about the suitability of this software for any purpose. It is provided "as is" without express or implied warranty.

ZERO-KNOWLEDGE SYSTEMS, INC. DISCLAIMS ALL WARRANTIES WITH REGARD TO THIS SOFTWARE, INCLUDING ALL IMPLIED WARRANTIES OF MERCHANTABILITY AND FITNESS, IN NO EVENT SHALL ZERO-KNOWLEDGE SYSTEMS, INC. BE LIABLE FOR ANY SPECIAL, INDIRECT OR CONSEQUENTIAL DAMAGES OR ANY DAMAGES WHATSOEVER RESULTING FROM LOSS OF USE, DATA OR PROFITS, WHETHER IN AN ACTION OF CONTRACT, NEGLIGENCE OR OTHER TORTUOUS ACTION, ARISING OUT OF OR IN CONNECTION WITH THE USE OR PERFORMANCE OF THIS SOFTWARE.

The implementation of The AES encryption algorithm in src/lib/crypto/aes has the following copyright:

Copyright © 2001, Dr Brian Gladman <brg@gladman.uk.net>, Worcester, UK. All rights reserved.

#### LICENSE TERMS

The free distribution and use of this software in both source and binary form is allowed (with or without changes) provided that:

1. distributions of this source code include the above copyright notice, this list of conditions and the following disclaimer;
2. distributions in binary form include the above copyright notice, this list of conditions and the following disclaimer in the documentation and/or other associated materials;
3. the copyright holder's name is not used to endorse products built using this software without specific written permission.

#### DISCLAIMER

This software is provided 'as is' with no explicit or implied warranties in respect of any properties, including, but not limited to, correctness and fitness for purpose.

The implementation of The RPCSEC\_GSS authentication flavor in src/lib/rpc has the following copyright:

Copyright © 2000 The Regents of the University of Michigan. All rights reserved.

Copyright © 2000 Dug Song <dugsong@UMICH.EDU>. All rights reserved, all wrongs reversed.

Redistribution and use in source and binary forms, with or without modification, are permitted provided that the following conditions are met:

1. Redistributions of source code must retain the above copyright notice, this list of conditions and the following disclaimer.
2. Redistributions in binary form must reproduce the above copyright notice, this list of conditions and the following disclaimer in the documentation and/or other materials provided with the distribution.
3. Neither the name of the University nor the names of its contributors may be used to endorse or promote products derived from this software without specific prior written permission.

THIS SOFTWARE IS PROVIDED "AS IS" AND ANY EXPRESS OR IMPLIED WARRANTIES, INCLUDING, BUT NOT LIMITED TO, THE IMPLIED WARRANTIES OF MERCHANTABILITY AND FITNESS FOR A PARTICULAR PURPOSE ARE DISCLAIMED. IN NO EVENT SHALL THE REGENTS OR CONTRIBUTORS BE LIABLE FOR ANY DIRECT, INDIRECT, INCIDENTAL, SPECIAL, EXEMPLARY, OR CONSEQUENTIAL DAMAGES (INCLUDING, BUT NOT LIMITED TO, PROCUREMENT OF SUBSTITUTE GOODS OR SERVICES; LOSS OF USE, DATA, OR PROFITS; OR BUSINESS INTERRUPTION) HOWEVER CAUSED AND ON ANY THEORY OF LIABILITY, WHETHER IN CONTRACT, STRICT LIABILITY, OR TORT (INCLUDING NEGLIGENCE OR OTHERWISE) ARISING IN ANY WAY OUT OF THE USE OF THIS SOFTWARE, EVEN IF ADVISED OF THE POSSIBILITY OF SUCH DAMAGE.

#### **zlib/libpng License**

Copyright notice:

© 1995-2004 Jean-loup Gailly and Mark Adler

This software is provided 'as-is', without any express or implied warranty. In no event will the authors be held liable for any damages arising from the use of this software.

Permission is granted to anyone to use this software for any purpose, including commercial applications, and to alter it and redistribute it freely, subject to the following restrictions:

1. The origin of this software must not be misrepresented; you must not claim that you wrote the original software. If you use this software in a product, an acknowledgment in the product documentation would be appreciated but is not required.
2. Altered source versions must be plainly marked as such, and must not be misrepresented as being the original software.
3. This notice may not be removed or altered from any source distribution.

Jean-loup Gailly      Mark Adler  
jloup@gzip.org      madler@alumni.caltech.edu

---

### **Pure-FTPd License**

Pure-FTPd is covered by the following license :

Copyright © 2001, 2002, 2003, 2004, 2005, 2006 Frank Denis <j@pureftpd.org> with the help of all Pure-FTPd contributors.

Permission to use, copy, modify, and distribute this software for any purpose with or without fee is hereby granted, provided that the above copyright notice and this permission notice appear in all copies.

THE SOFTWARE IS PROVIDED "AS IS" AND THE AUTHOR DISCLAIMS ALL WARRANTIES WITH REGARD TO THIS SOFTWARE INCLUDING ALL IMPLIED WARRANTIES OF MERCHANTABILITY AND FITNESS. IN NO EVENT SHALL THE AUTHOR BE LIABLE FOR ANY SPECIAL, DIRECT, INDIRECT, OR CONSEQUENTIAL DAMAGES OR ANY DAMAGES WHATSOEVER RESULTING FROM LOSS OF USE, DATA OR PROFITS, WHETHER IN AN ACTION OF CONTRACT, NEGLIGENCE OR OTHER TORTIOUS ACTION, ARISING OUT OF OR IN CONNECTION WITH THE USE OR PERFORMANCE OF THIS SOFTWARE.

The `bsd-glob.c`, `bsd-glob.h`, `bsd-realpath.c`, `bsd-getopt_long.c` and `bsd-getopt_long.h` source codes are based upon the OpenBSD and NetBSD projects and they are covered by the BSD license.

The original license is enclosed at the beginning of the related files.

### **OpenSLP License**

The following copyright and license is applicable to the entire OpenSLP project (`libslp`, `slpd`, and related documentation):

Copyright © 2000 Caldera Systems, Inc  
All rights reserved.

Redistribution and use in source and binary forms, with or without modification, are permitted provided that the following conditions are met:

Redistributions of source code must retain the above copyright notice, this list of conditions and the following disclaimer.

Redistributions in binary form must reproduce the above copyright notice, this list of conditions and the following disclaimer in the documentation and/or other materials provided with the distribution.

Neither the name of Caldera Systems nor the names of its contributors may be used to endorse or promote products derived from this software without specific prior written permission.

THIS SOFTWARE IS PROVIDED BY THE COPYRIGHT HOLDERS AND CONTRIBUTORS "AS IS" AND ANY EXPRESS OR IMPLIED WARRANTIES, INCLUDING, BUT NOT LIMITED TO, THE IMPLIED WARRANTIES OF MERCHANTABILITY AND FITNESS FOR A PARTICULAR PURPOSE ARE DISCLAIMED. IN NO EVENT SHALL THE CALDERA SYSTEMS OR CONTRIBUTORS BE LIABLE FOR ANY DIRECT, INDIRECT, INCIDENTAL, SPECIAL, EXEMPLARY, OR CONSEQUENTIAL DAMAGES (INCLUDING, BUT NOT LIMITED TO, PROCUREMENT OF SUBSTITUTE GOODS OR SERVICES; LOSS OF USE, DATA, OR PROFITS; OR BUSINESS INTERRUPTION) HOWEVER CAUSED AND ON ANY THEORY OF LIABILITY, WHETHER IN CONTRACT, STRICT LIABILITY, OR TORT (INCLUDING NEGLIGENCE OR OTHERWISE) ARISING IN ANY WAY OUT OF THE USE OF THIS SOFTWARE, EVEN IF ADVISED OF THE POSSIBILITY OF SUCH DAMAGE.

### **Net-SNMP License**

Various copyrights apply to this package, listed in 4 separate parts below. Please make sure that you read all the parts. Up until 2001, the project was based at UC Davis, and the first part covers all code written during this time. From 2001 onwards, the project has been based at SourceForge, and Networks Associates Technology, Inc hold the copyright on behalf of the wider Net-SNMP community, covering all derivative work done since then. An additional copyright section has been added as Part 3 below also under a BSD license for the work contributed by Cambridge Broadband Ltd. to the project since 2001.

An additional copyright section has been added as Part 4 below also under a BSD license for the work contributed by Sun Microsystems, Inc. to the project since 2003.

Code has been contributed to this project by many people over the years it has been in development, and a full list of contributors can be found in the README file under the THANKS section.

Part 1: CMU/UCD copyright notice: (BSD like)

Copyright 1989, 1991, 1992 by Carnegie Mellon University

Derivative Work - 1996, 1998-2000

Copyright 1996, 1998-2000 The Regents of the University of California

All Rights Reserved

Permission to use, copy, modify and distribute this software and its documentation for any purpose and without fee is hereby granted, provided that the above copyright notice appears in all copies and that both that copyright notice and this permission notice appear in supporting documentation, and that the name of CMU and The Regents of the University of California not be used in advertising or publicity pertaining to distribution of the software without specific written permission.

CMU AND THE REGENTS OF THE UNIVERSITY OF CALIFORNIA DISCLAIM ALL WARRANTIES WITH REGARD TO THIS SOFTWARE, INCLUDING ALL IMPLIED WARRANTIES OF MERCHANTABILITY AND FITNESS. IN NO EVENT SHALL CMU OR THE REGENTS OF THE UNIVERSITY OF CALIFORNIA BE LIABLE FOR ANY SPECIAL, INDIRECT OR CONSEQUENTIAL DAMAGES OR ANY DAMAGES WHATSOEVER RESULTING FROM THE LOSS OF USE, DATA OR PROFITS, WHETHER IN AN ACTION OF CONTRACT, NEGLIGENCE OR OTHER TORTIOUS ACTION, ARISING OUT OF OR IN CONNECTION WITH THE USE OR PERFORMANCE OF THIS SOFTWARE.

Part 2: Networks Associates Technology, Inc copyright notice (BSD)

Copyright © 2001-2003, Networks Associates Technology, Inc  
All rights reserved.

Redistribution and use in source and binary forms, with or without modification, are permitted provided that the following conditions are met:

- Redistributions of source code must retain the above copyright notice, this list of conditions and the following disclaimer.
- Redistributions in binary form must reproduce the above copyright notice, this list of conditions and the following disclaimer in the documentation and/or other materials provided with the distribution.
- Neither the name of the Networks Associates Technology, Inc nor the names of its contributors may be used to endorse or promote products derived from this software without specific prior written permission.

THIS SOFTWARE IS PROVIDED BY THE COPYRIGHT HOLDERS AND CONTRIBUTORS "AS IS" AND ANY EXPRESS OR IMPLIED WARRANTIES, INCLUDING, BUT NOT LIMITED TO, THE IMPLIED WARRANTIES OF MERCHANTABILITY AND FITNESS FOR A PARTICULAR PURPOSE ARE DISCLAIMED. IN NO EVENT SHALL THE COPYRIGHT HOLDERS OR CONTRIBUTORS BE LIABLE FOR ANY DIRECT, INDIRECT, INCIDENTAL, SPECIAL, EXEMPLARY, OR CONSEQUENTIAL DAMAGES (INCLUDING, BUT NOT LIMITED TO, PROCUREMENT OF SUBSTITUTE GOODS OR SERVICES; LOSS OF USE, DATA, OR PROFITS; OR BUSINESS INTERRUPTION) HOWEVER CAUSED AND ON ANY THEORY OF LIABILITY, WHETHER IN CONTRACT, STRICT LIABILITY, OR TORT (INCLUDING NEGLIGENCE OR OTHERWISE) ARISING IN ANY WAY OUT OF THE USE OF THIS SOFTWARE, EVEN IF ADVISED OF THE POSSIBILITY OF SUCH DAMAGE.

Part 3: Cambridge Broadband Ltd. copyright notice (BSD)

Portions of this code are copyright © 2001-2003, Cambridge Broadband Ltd.  
All rights reserved.

Redistribution and use in source and binary forms, with or without modification, are permitted provided that the following conditions are met:

- Redistributions of source code must retain the above copyright notice, this list of conditions and the following disclaimer.
- Redistributions in binary form must reproduce the above copyright notice, this list of conditions and the following disclaimer in the documentation and/or other materials provided with the distribution.
- The name of Cambridge Broadband Ltd. may not be used to endorse or promote products derived from this software without specific prior written permission.

THIS SOFTWARE IS PROVIDED BY THE COPYRIGHT HOLDER "AS IS" AND ANY EXPRESS OR IMPLIED WARRANTIES, INCLUDING, BUT NOT LIMITED TO, THE IMPLIED WARRANTIES OF MERCHANTABILITY AND FITNESS FOR A PARTICULAR PURPOSE ARE DISCLAIMED. IN NO EVENT SHALL THE COPYRIGHT HOLDER BE LIABLE FOR ANY DIRECT, INDIRECT, INCIDENTAL, SPECIAL, EXEMPLARY, OR CONSEQUENTIAL DAMAGES (INCLUDING, BUT NOT LIMITED TO, PROCUREMENT OF SUBSTITUTE GOODS OR SERVICES; LOSS OF USE, DATA, OR PROFITS; OR BUSINESS INTERRUPTION) HOWEVER CAUSED AND ON ANY THEORY OF LIABILITY, WHETHER IN CONTRACT, STRICT LIABILITY, OR TORT (INCLUDING NEGLIGENCE OR OTHERWISE) ARISING IN ANY WAY OUT OF THE USE OF THIS SOFTWARE, EVEN IF ADVISED OF THE POSSIBILITY OF SUCH DAMAGE.

Part 4: Sun Microsystems, Inc. copyright notice (BSD)

Copyright © 2003 Sun Microsystems, Inc., 4150 Network Circle, Santa Clara, California 95054, U.S.A. All rights reserved.

Use is subject to license terms below.

This distribution may include materials developed by third parties



Sun, Sun Microsystems, the Sun logo and Solaris are trademarks or registered trademarks of Sun Microsystems, Inc. in the U.S. and other countries.

Redistribution and use in source and binary forms, with or without modification, are permitted provided that the following conditions are met:

- Redistributions of source code must retain the above copyright notice, this list of conditions and the following disclaimer.
- Redistributions in binary form must reproduce the above copyright notice, this list of conditions and the following disclaimer in the documentation and/or other materials provided with the distribution.
- Neither the name of the Sun Microsystems, Inc. nor the names of its contributors may be used to endorse or promote products derived from this software without specific prior written permission.

THIS SOFTWARE IS PROVIDED BY THE COPYRIGHT HOLDERS AND CONTRIBUTORS "AS IS" AND ANY EXPRESS OR IMPLIED WARRANTIES, INCLUDING, BUT NOT LIMITED TO, THE IMPLIED WARRANTIES OF MERCHANTABILITY AND FITNESS FOR A PARTICULAR PURPOSE ARE DISCLAIMED. IN NO EVENT SHALL THE COPYRIGHT HOLDERS OR CONTRIBUTORS BE LIABLE FOR ANY DIRECT, INDIRECT, INCIDENTAL, SPECIAL, EXEMPLARY, OR CONSEQUENTIAL DAMAGES (INCLUDING, BUT NOT LIMITED TO, PROCUREMENT OF SUBSTITUTE GOODS OR SERVICES; LOSS OF USE, DATA, OR PROFITS; OR BUSINESS INTERRUPTION) HOWEVER CAUSED AND ON ANY THEORY OF LIABILITY, WHETHER IN CONTRACT, STRICT LIABILITY, OR TORT (INCLUDING NEGLIGENCE OR OTHERWISE) ARISING IN ANY WAY OUT OF THE USE OF THIS SOFTWARE, EVEN IF ADVISED OF THE POSSIBILITY OF SUCH DAMAGE.

Part 5: Sparta, Inc copyright notice (BSD)

Copyright © 2003-2004, Sparta, Inc  
All rights reserved.

Redistribution and use in source and binary forms, with or without modification, are permitted provided that the following conditions are met:

- Redistributions of source code must retain the above copyright notice, this list of conditions and the following disclaimer.
- Redistributions in binary form must reproduce the above copyright notice, this list of conditions and the following disclaimer in the documentation and/or other materials provided with the distribution.
- Neither the name of the Networks Associates Technology, Inc nor the names of its contributors may be used to endorse or promote products derived from this software without specific prior written permission.

THIS SOFTWARE IS PROVIDED BY THE COPYRIGHT HOLDERS AND CONTRIBUTORS "AS IS" AND ANY EXPRESS OR IMPLIED WARRANTIES, INCLUDING, BUT NOT LIMITED TO, THE IMPLIED WARRANTIES OF MERCHANTABILITY AND FITNESS FOR A PARTICULAR PURPOSE ARE DISCLAIMED. IN NO EVENT SHALL THE COPYRIGHT HOLDERS OR CONTRIBUTORS BE LIABLE FOR ANY DIRECT, INDIRECT, INCIDENTAL, SPECIAL, EXEMPLARY, OR CONSEQUENTIAL DAMAGES (INCLUDING, BUT NOT LIMITED TO, PROCUREMENT OF SUBSTITUTE GOODS OR SERVICES; LOSS OF USE, DATA, OR PROFITS; OR BUSINESS INTERRUPTION) HOWEVER CAUSED AND ON ANY THEORY OF LIABILITY, WHETHER IN CONTRACT, STRICT LIABILITY, OR TORT (INCLUDING NEGLIGENCE OR OTHERWISE) ARISING IN ANY WAY OUT OF THE USE OF THIS SOFTWARE, EVEN IF ADVISED OF THE POSSIBILITY OF SUCH DAMAGE.

#### **cyrus-sasl License**

CMU libsasl  
Tim Martin  
Rob Earhart  
Rob Siemborski

Copyright © 1998-2003 Carnegie Mellon University. All rights reserved.

Redistribution and use in source and binary forms, with or without modification, are permitted provided that the following conditions are met:

1. Redistributions of source code must retain the above copyright notice, this list of conditions and the following disclaimer.
2. Redistributions in binary form must reproduce the above copyright notice, this list of conditions and the following disclaimer in the documentation and/or other materials provided with the distribution.
3. The name "Carnegie Mellon University" must not be used to endorse or promote products derived from this software without prior written permission. For permission or any other legal details, please contact  
Office of Technology Transfer  
Carnegie Mellon University  
5000 Forbes Avenue  
Pittsburgh, PA 15213-3890

(412) 268-4387, fax: (412) 268-7395  
tech-transfer@andrew.cmu.edu

4. Redistributions of any form whatsoever must retain the following acknowledgment:  
"This product includes software developed by Computing Services at Carnegie Mellon University (<http://www.cmu.edu/computing/>)."

CARNEGIE MELLON UNIVERSITY DISCLAIMS ALL WARRANTIES WITH REGARD TO THIS SOFTWARE, INCLUDING ALL IMPLIED WARRANTIES OF MERCHANTABILITY AND FITNESS, IN NO EVENT SHALL CARNEGIE MELLON UNIVERSITY BE LIABLE FOR ANY SPECIAL, INDIRECT OR CONSEQUENTIAL DAMAGES OR ANY DAMAGES WHATSOEVER RESULTING FROM LOSS OF USE, DATA OR PROFITS, WHETHER IN AN ACTION OF CONTRACT, NEGLIGENCE OR OTHER TORTIOUS ACTION, ARISING OUT OF OR IN CONNECTION WITH THE USE OR PERFORMANCE OF THIS SOFTWARE.

#### **dhclient License**

Copyright © 2004 by Internet Systems Consortium, Inc. ("ISC")  
Copyright © 1995-2003 by Internet Software Consortium

Permission to use, copy, modify, and distribute this software for any purpose with or without fee is hereby granted, provided that the above copyright notice and this permission notice appear in all copies.

THE SOFTWARE IS PROVIDED "AS IS" AND ISC DISCLAIMS ALL WARRANTIES WITH REGARD TO THIS SOFTWARE INCLUDING ALL IMPLIED WARRANTIES OF MERCHANTABILITY AND FITNESS. IN NO EVENT SHALL ISC BE LIABLE FOR ANY SPECIAL, DIRECT, INDIRECT, OR CONSEQUENTIAL DAMAGES OR ANY DAMAGES WHATSOEVER RESULTING FROM LOSS OF USE, DATA OR PROFITS, WHETHER IN AN ACTION OF CONTRACT, NEGLIGENCE OR OTHER TORTIOUS ACTION, ARISING OUT OF OR IN CONNECTION WITH THE USE OR PERFORMANCE OF THIS SOFTWARE.

Internet Systems Consortium, Inc.  
950 Charter Street  
Redwood City, CA 94063  
<info@isc.org>  
<http://www.isc.org/>

#### **expat License**

Copyright © 1998, 1999, 2000 Thai Open Source Software Center Ltd and Clark Cooper  
Copyright © 2001, 2002 Expat maintainers.

Permission is hereby granted, free of charge, to any person obtaining a copy of this software and associated documentation files (the Software), to deal in the Software without restriction, including without limitation the rights to use, copy, modify, merge, publish, distribute, sublicense, and/or sell copies of the Software, and to permit persons to whom the Software is furnished to do so, subject to the following conditions:

The above copyright notice and this permission notice shall be included in all copies or substantial portions of the Software.

THE SOFTWARE IS PROVIDED "AS IS", WITHOUT WARRANTY OF ANY KIND, EXPRESS OR IMPLIED, INCLUDING BUT NOT LIMITED TO THE WARRANTIES OF MERCHANTABILITY, FITNESS FOR A PARTICULAR PURPOSE AND NONINFRINGEMENT. IN NO EVENT SHALL THE AUTHORS OR COPYRIGHT HOLDERS BE LIABLE FOR ANY CLAIM, DAMAGES OR OTHER LIABILITY, WHETHER IN AN ACTION OF CONTRACT, TORT OR OTHERWISE, ARISING FROM, OUT OF OR IN CONNECTION WITH THE SOFTWARE OR THE USE OR OTHER DEALINGS IN THE SOFTWARE.

#### **OpenSSL Statement**

##### *OpenSSL license*

Copyright © 1998-2000 The OpenSSL Project. All rights reserved. Redistribution and use in source and binary forms, with or without modification, are permitted provided that the following conditions are met:

1. Redistributions of source code must retain the above copyright notice, this list of conditions and the following disclaimer.
2. Redistributions in binary form must reproduce the above copyright notice, this list of conditions and the following disclaimer in the documentation and/or other materials provided with the distribution.
3. All advertising materials mentioning features or use of this software must display the following acknowledgment: This product includes software developed by the OpenSSL Project for use in the OpenSSL Toolkit. (<http://www.openssl.org>)
4. The names "OpenSSL Toolkit" and "OpenSSL Project" must not be used to endorse or promote products derived from this software without prior written permission. For written permission, please contact [openssl-core@openssl.org](mailto:openssl-core@openssl.org)

5. Products derived from this software may not be called "OpenSSL" nor may "OpenSSL" appear in their names without prior written permission of the OpenSSL Project.
6. Redistributions of any form whatsoever must retain the following acknowledgment: "This product includes software developed by the OpenSSL Project for use in the OpenSSL Toolkit (<http://www.openssl.org>)"

THIS SOFTWARE IS PROVIDED BY THE OpenSSL PROJECT "AS IS" AND ANY EXPRESSED OR IMPLIED WARRANTIES, INCLUDING, BUT NOT LIMITED TO, THE IMPLIED WARRANTIES OF MERCHANTABILITY AND FITNESS FOR A PARTICULAR PURPOSE ARE DISCLAIMED. IN NO EVENT SHALL THE OpenSSL PROJECT OR ITS CONTRIBUTORS BE LIABLE FOR ANY DIRECT, INDIRECT, INCIDENTAL, SPECIAL, EXEMPLARY, OR CONSEQUENTIAL DAMAGES (INCLUDING, BUT NOT LIMITED TO, PROCUREMENT OF SUBSTITUTE GOODS OR SERVICES; LOSS OF USE, DATA, OR PROFITS; OR BUSINESS INTERRUPTION) HOWEVER CAUSED AND ON ANY THEORY OF LIABILITY, WHETHER IN CONTRACT, STRICT LIABILITY, OR TORT (INCLUDING NEGLIGENCE OR OTHERWISE) ARISING IN ANY WAY OUT OF THE USE OF THIS SOFTWARE, EVEN IF ADVISED OF THE POSSIBILITY OF SUCH DAMAGE. This product includes cryptographic software written by Eric Young ([ey@cryptsoft.com](mailto:ey@cryptsoft.com)). This product includes software written by Tim Hudson ([tjh@cryptsoft.com](mailto:tjh@cryptsoft.com)).

#### *SSLey license*

Copyright © 1995-1998 Eric Young ([ey@cryptsoft.com](mailto:ey@cryptsoft.com)) All rights reserved. This package is an SSL implementation written by Eric Young ([ey@cryptsoft.com](mailto:ey@cryptsoft.com)). The implementation was written so as to conform with Netscapes SSL. This library is free for commercial and non-commercial use as long as the following conditions are adhered to. The following conditions apply to all code found in this distribution, be it the RC4, RSA, lhash, DES, etc., code; not just the SSL code. The SSL documentation included with this distribution is covered by the same copyright terms except that the holder is Tim Hudson ([tjh@cryptsoft.com](mailto:tjh@cryptsoft.com)).

Copyright remains Eric Young's, and as such any Copyright notices in the code are not to be removed. If this package is used in a product, Eric Young should be given attribution as the author of the parts of the library used. This can be in the form of a textual message at program startup or in documentation (online or textual) provided with the package. Redistribution and use in source and binary forms, with or without modification, are permitted provided that the following conditions are met:

1. Redistributions of source code must retain the copyright notice, this list of conditions and the following disclaimer.
2. Redistributions in binary form must reproduce the above copyright notice, this list of conditions and the following disclaimer in the documentation and/or other materials provided with the distribution.
3. All advertising materials mentioning features or use of this software must display the following acknowledgement: "This product includes cryptographic software written by Eric Young ([ey@cryptsoft.com](mailto:ey@cryptsoft.com))". The word 'cryptographic' can be left out if the routines from the library being used are not cryptographic related :-).
4. If you include any Windows specific code (or a derivative thereof) from the apps directory (application code) you must include an acknowledgement: "This product includes software written by Tim Hudson ([tjh@cryptsoft.com](mailto:tjh@cryptsoft.com))"

THIS SOFTWARE IS PROVIDED BY ERIC YOUNG "AS IS" AND ANY EXPRESS OR IMPLIED WARRANTIES, INCLUDING, BUT NOT LIMITED TO, THE IMPLIED WARRANTIES OF MERCHANTABILITY AND FITNESS FOR A PARTICULAR PURPOSE ARE DISCLAIMED. IN NO EVENT SHALL THE AUTHOR OR CONTRIBUTORS BE LIABLE FOR ANY DIRECT, INDIRECT, INCIDENTAL, SPECIAL, EXEMPLARY, OR CONSEQUENTIAL DAMAGES (INCLUDING, BUT NOT LIMITED TO, PROCUREMENT OF SUBSTITUTE GOODS OR SERVICES; LOSS OF USE, DATA, OR PROFITS; OR BUSINESS INTERRUPTION) HOWEVER CAUSED AND ON ANY THEORY OF LIABILITY, WHETHER IN CONTRACT, STRICT LIABILITY, OR TORT (INCLUDING NEGLIGENCE OR OTHERWISE) ARISING IN ANY WAY OUT OF THE USE OF THIS SOFTWARE, EVEN IF ADVISED OF THE POSSIBILITY OF SUCH DAMAGE. The licence and distribution terms for any publicly available version or derivative of this code cannot be changed. i.e. this code cannot simply be copied and put under another distribution licence [including the GNU Public Licence.

#### 版权所有

© 2010 柯尼卡美能达商用科技株式会社保留所有权利。

#### 备注

- 未经允许不得复制使用说明书的部分或全部。
- 柯尼卡美能达商用科技株式会社对任何由于使用本打印系统或使用说明书而导致的事件均不承担责任。
- 使用说明书中包含的信息可不经通知而作出修改。
- 柯尼卡美能达商用科技株式会社保留打印机驱动程序的版权。

## 软件许可证协议

本软件包包含由柯尼卡美能达商用科技株式会社（KMBT）提供的下列材料：作为打印系统一部分而包括的软件（“打印软件”）、数字编码机器可读概述数据（以特殊格式及加密形式编码）（“字体程序”）、在计算机系统上运行的其它软件（与打印软件一并使用）（“主机软件”）以及有关的说明性书面材料（“文献”）。术语“软件”应用于说明打印软件、字体程序与/或主机软件，并包括任何升级、修改版本、添加、以及软件的副本。

您按照本协议的条款获得软件许可证。

KMBT 授予您非排他性从属许可证，以使用软件及文献，但您必须同意以下各项：

1. 您必须把软件以及随附的字体程序（用于在许可的输出装置上进行成像）完全用于您的内部业务用途。
2. 除在上述第 1 节中规定的字体程序的许可证以外，您可以使用 **Roman Font Programs** 在显示器或监视器上复制字母、数字、字符与符号（“字体”）的权重、风格与版本，用于您的内部业务用途。
3. 如未安装备份软件或用于任何计算机，则可以制作一份主机软件的备份。尽管受到上述限制，可以在任何数目的计算机上安装，完全用于运行打印软件的一个或多个打印系统。
4. 可以按照本协议将其权利分配给关于此类软件与文献的所有许可证持有人权利与利益的受让人（“受让人”），条件是此类别软件与文献（受让人同意遵守本协议的所有条款与条件）的所有副本移交给受让人。
5. 同意不得修改、改编或翻译软件与文献。
6. 同意不会对软件尝试改动、分解、解密、逆向工程或反编译。
7. 软件及文献（以及其任何复制）的所有权与拥有权属于 KMBT 及其许可证颁发方。
8. 应按照普遍认可的商标做法使用商标，包括标识商标拥有者的名称。商标仅可用于识别由软件所产生的打印输出。此类商标使用不会使您具有该商标的任何拥有权。
9. 不得出租、租赁、颁发从属许可证、借出或移交软件许可证不使用的版本或副本、或任何未使用介质所包含的软件（如上所述的全部软件与文献的永久移交的一部分除外）。
10. 在任何情况下，KMBT 或其许可证颁发方对任何因果性、偶然、间接、惩罚性或特殊的损害（包括任何利润损失或存款损失）（即使 KMBT 已获知此类损害的可能性）、或任何由第三方提出的任何索赔要求均不对您承担责任。KMBT 或其许可证颁发方放弃所有有关软件的明示或暗示担保（包括但不限于某特定用途的适销性、适合性暗示担保，第三方权利的所有权与不侵犯担保）。某些国家或司法机构不允许排除或限制偶然、因果性或特殊损害，因此上述限制条款可能对您不适用。
11. 对政府最终用户的注意事项：软件是一种“商业物品”，该术语在 48 C.F.R.2.101 中界定，由“商业计算机软件”与“商业计算机软件文献”组成，此类术语用于 48 C.F.R. 12.212。与 48 C.F.R. 12.212 及 48 C.F.R. 227.7202-1 至 227.7202-4 相一致，所有美国政府最终用户取得软件时仅具有此处所规定的权利。
12. 您同意不会以违反有关任何国家的出口控制的任何适用法律及规定的任何形式出口本软件。

# 目录

## 前言

Energy Star® .....	x-2
商标 / 版权所有 .....	x-3
软件许可证协议 .....	x-26
目录 .....	x-27
安全信息 .....	x-29
规定注意事项 .....	x-33
安全警告注意事项和标签 .....	x-38
用户特殊注意事项 .....	x-39
空间要求 .....	x-42
操作注意事项 .....	x-43
关于复印的法律限制 .....	x-44
使用说明书的介绍 .....	x-45
可用功能 .....	x-47
控制面板 .....	x-49
打开 / 关闭机器电源 .....	x-50
装入纸张 .....	x-52
清除卡纸 .....	x-60
更换耗材 .....	x-63
选购件 .....	x-69

## 1 基本操作

1.1 基本复印操作 .....	1-2
1.2 基本打印操作 .....	1-5
1.3 基本传真操作 .....	1-9
1.4 基本扫描操作 .....	1-12

## 2 有用的复印操作

2.1 复印时减少纸张使用 .....	2-2
2.2 在不同尺寸的纸张放大 / 缩小打印 .....	2-5
2.3 在信封上复印 .....	2-7
2.4 轻松调出经常使用的功能 .....	2-10
2.5 检查打印数 .....	2-13
2.6 降低电量消耗 .....	2-15

## 3 有用的打印操作

3.1 选择纸张 .....	3-2
3.2 管理和限制打印 .....	3-5
3.3 打印时减少纸张使用 .....	3-6
3.4 调整打印位置 .....	3-7
3.5 打印时添加文字和图像 .....	3-8
3.6 调整图像质量 .....	3-9
3.7 使用打印机字体 .....	3-10

4	有用的传真操作	
4.1	注册经常使用的传真号码 .....	4-2
4.2	检查目前为止执行的传真操作 .....	4-7
4.3	同时向多个收件人传送 .....	4-9
4.4	选择注册的传送源信息 .....	4-13
4.5	扫描要发送的原稿 .....	4-15
4.6	使用从收件人发出的命令发送文件 .....	4-17
4.7	降低通信成本 .....	4-19
4.8	降低通信成本（使用 Internet/ 内联网） .....	4-21
4.9	通过电子邮件发送原稿 .....	4-23
4.10	降低打印成本 .....	4-25
4.11	发送机密文件 .....	4-27
4.12	转发接收数据 .....	4-29
4.13	直接从计算机传真数据 .....	4-30
4.14	从计算机注册单触目的地 .....	4-31
5	有用的网络扫描操作	
5.1	注册经常使用的目的地 .....	5-2
5.2	传送精细文字和清晰图像 .....	5-7
5.3	使用所选颜色和文件类型设置传送 .....	5-11
5.4	使用已调节背景颜色传送 .....	5-13
5.5	向多个收件人传送 .....	5-15
5.6	通过电子邮件发送文件 .....	5-18
5.7	检查目前为止执行的传送 .....	5-20
6	故障排除	
6.1	故障排除 .....	6-2
7	用户设置参数	
7.1	显示用户设置屏幕 .....	7-2
7.2	可以指定的设置 .....	7-3
8	索引	

## 安全信息

本节介绍关于操作和维护本机的详细操作说明。要让本机取得最佳使用效果，所有操作人员均应仔细阅读并遵守本使用说明书中的操作说明。

在连接机器与电源之前，请阅读下列部分。它包含与用户安全及防止设备故障相关的重要信息。

请将本使用说明书存放在机器附近便于取阅的位置。

请务必遵照本使用说明书各章节中的所有注意事项进行操作。

KM\_Ver.02C





备注

本节内容的有些部分可能会与购买的产品无法一一对应。

### 警告与注意符号

注意标志或本手册使用下列标识进行安全注意事项的等级分类。

 <b>警告</b>	无视此警告可能会导致严重人身伤害甚至死亡。
 <b>注意</b>	无视此注意事项可能会导致人身伤害或财物损坏。

### 符号的含义

-  三角形表示危险，应采取相应预防措施。
-  此符号警告可能会导致灼伤。
-  对角线表示禁止采取该操作。
-  此符号就拆解设备给出警告。
-  黑色圆圈表示必须采取该操作。
-  此符号表示必须切断设备电源。

### 拆卸与改装

#### 警告

- 请勿试图拆卸固定在本机上的盖子和面板。有些产品内部配有高压零件或激光束光源，如此可能会导致电击或致盲。



- 请勿改装本机，否则可能会导致火灾、电击或停机。如果本机采用了激光器，擅自改装本机，激光束光源可能会致盲。



## 电源线

### ⚠ 警告

- 仅应使用产品包装箱内附带的电源线。如果未附带电源线，仅应使用“电源线技术规格”中规定的电线和插头。如果未能使用此种电源线，可能会导致火灾或电击。
- 产品包装箱内附带的电源线仅应用于本机，切勿将它用于任何其它产品。如果未能遵照此注意事项，可能会导致火灾或电击。
- 请勿刮伤、磨损、加热、扭曲、弯折、拉伸、损坏电源线，或在上面放置重物。使用损坏的电源线（电芯暴露、电线破损等）可能会导致火灾或停机。如果发现任何上述情况，请立即关掉电源开关，从电源插座拔下电源线插头，然后致电授权维修技术人员报修。

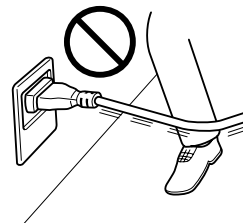

## 电源

### ⚠ 警告

- 仅应使用规定的电源电压。如果未能如此，可能会导致火灾或电击。
- 将电源插头直接插入与插头配置相同的电源插座中。使用适配器会导致产品所连接的电源不适当（电压、电流容量、接地），并可能造成火灾或触电。如未配备适当的电源插座，顾客应请具有资格的电气技师进行安装。
- 原则上不要使用多重插座适配器或延长线。使用适配器或延长线可能会导致火灾或触电。如果必须使用延长线，请与授权维修技术人员联系。
- 在同一电源插座上连接其他设备之前，请咨询授权的维修技术人员。过载可能会导致火灾。



### ⚠ 注意

- 插座必须靠近设备并易于接近。否则不能在发生紧急情况时拔出电源插头。





## 电源插头

### ⚠ 警告

- 请勿在手潮湿时插、拔电源线，否则可能会导致电击。



- 将电源线插头完全插入电源插座。如果未能如此，可能会导致火灾或电击。



### ⚠ 注意

- 拔出插头时不要拖拉电源线。直接拉电源线可能会损坏它，并因此导致火灾或电击。



- 每年至少一次从插座上拔出电源插头，并清洁插头端子之间的区域。插头端子之间积聚的灰尘可能会导致火灾。



## 接地

### ⚠ 警告

- 将电源插头插入配备接地端子的电源插座。



## 安装

### ⚠ 警告

- 请勿将花瓶或其它盛水的容器、金属夹或其它小件金属物品放在本机上。如果不慎将水泼入或金属物品掉入本机内部，可能会导致火灾、电击或停机。如果小金属件、水或其它类似异物不慎进入本机，请立即关掉电源开关，从电源插座拔下电源线插头，然后致电授权维修技术人员报修。

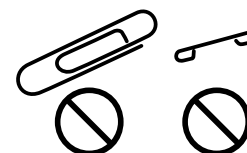

### ⚠ 注意

- 安装本机之后，请将它放到稳固的基座上。如果本机发生移位或翻倒，可能会导致人身伤害。



- 请勿将本机放在多尘或有煤烟、蒸汽的位置，也不要放在厨房灶台、浴室或增湿器旁边。否则可能会导致火灾、电击或停机。



- 请勿将本机放在不稳或倾斜的工作台面上，也不要放在大幅抖动和震动的位置。否则它可能会掉落或翻倒，并因此导致人身伤害或机械故障。



- 请勿用任何物体堵住本机的通风孔。否则本机内部可能会聚集热量，并因此导致火灾或故障。



- 请勿在本机附近使用易燃喷雾剂、液体或气体，否则可能会导致火灾。



## 通风

### ⚠ 注意

- 在通风不佳的房间内长时间使用本机或者大量进行复印 / 打印的情况下，有可能出现排气异味，请充分通风。



## 对故障采取的对策

### ⚠ 警告

- 如果本机变得异常灼热、冒烟、散发异味、产生异常噪音，请勿继续使用。此时请立即关掉电源开关，从电源插座拔下电源线插头，然后致电维修技术人员报修。如果不管这些继续使用，可能会导致火灾或电击。



- 如果本机不慎掉落或壳盖损坏，请勿继续使用。此时请立即关掉电源开关，从电源插座拔下电源线插头，然后致电维修技术人员报修。如果不管这些继续使用，可能会导致火灾或电击。



### ⚠ 注意

- 本机内部存在高温区，可能会导致灼伤。检查本机内部故障（如送纸故障）时，请勿触摸贴有“Caution HOT”注意标签的位置（定影单元周围等）。



## 耗材

### ⚠ 警告

- 请勿将碳粉盒或碳粉扔入明火。碳粉受热可能会飞散，并因此导致灼伤或其它伤害。



### ⚠ 注意

- 请勿将碳粉单元或感光鼓单元遗留在儿童方便触及的位置。舔食或吞咽这些物品可能会损害健康。



- 请勿将碳粉单元和PC感光鼓单元放在软盘或手表等易受磁力影响的物体旁边。否则会导致这些产品发生故障。



## 移动机器时

### ⚠ 注意

- 只要移动本机，请务必拔出电源线和其它电缆线。如果未能如此，可能会损坏电源线或电缆线，并因此导致火灾、电击或停机。



- 移动本机时，请务必拿住用户指南或其它文件中指明的位置。如果本机不慎翻倒，可能会导致严重人身伤害。同时本机也可能被损坏或发生故障。



未安装选购的 FK-507 传真装置时：

## 在连续假期之前

### ⚠ 注意

- 如长时间不使用本产品，应将插头拔出。



## 规定注意事项

### **CE Marking (Declaration of Conformity) for users of the European Union (EU)**

This product complies with the following EU directives:  
2006/95/EC, 2004/108/EC and 1999/5/EC directives.

This declaration is valid for the area of the European Union.

This device must be used with a shielded interface cable. The use of non-shielded cables is likely to result in interference with radio communications and is prohibited under CISPR rules and local rules.

NOTE: Optional Authentication Unit AU-201 (IC Card Reader/Writer)

This product is wireless system equipment (Short-Range Device) which the R & TTE directive (1999/5/EC) covers. Frequency of operation is 13.56 MHz.

### **USER INSTRUCTIONS FCC PART 15 - RADIO FREQUENCY DEVICES (for U.S.A. users)**

NOTE: This equipment has been tested and found to comply with the limits for a Class A digital device, pursuant to Part 15 of the FCC Rules.

These limits are designed to provide reasonable protection against harmful interference when the equipment is operated in a commercial environment. This equipment generates, uses and can radiate radio frequency energy and, if not installed and used in accordance with the instruction manual, may cause harmful interference to radio communications. Operation of this equipment in a residential area is likely to cause harmful interference in which case the user will be required to correct the interference at his own expense.

WARNING: The design and production of this unit conform to FCC regulations, and any changes or modifications must be registered with the FCC and are subject to FCC control. Any changes made by the purchaser or user without first contacting the manufacturer will be subject to penalty under FCC regulations.

This device must be used with a shielded interface cable. The use of non-shielded cables is likely to result in interference with radio communications and is prohibited under FCC rules.

### **INTERFERENCE-CAUSING EQUIPMENT STANDARD (ICES-003 ISSUE 4) (for Canada users)**

This Class A digital apparatus complies with Canadian ICES-003.

Cet appareil numérique de la classe A est conforme à la norme NMB-003 du Canada.

对于不受 B 级规定约束的国家中的用户

#### **警告**

这是 A 级产品。在民用环境中本产品可导致射频干扰，此时用户可能需要采取适当的措施。

本机必须使用带屏蔽的接口电缆。使用非屏蔽电缆可能会干扰无线电通信，这在 CISPR 及地方规定中是被禁止的。

#### **激光安全**

本机属于使用激光器进行工作的数字设备。根据本使用说明书中的操作说明使用本机提供的激光器，没有可能导致任何危险。

由于激光器辐射的放射线被完全限制在保护罩内，在用户操作的任何阶段，激光束均无法从本机逸出。

本机经鉴定属于 1 级激光产品：这意味着本机不会产生危险的激光辐射。

#### **内部激光辐射**

最大平均辐射功率：打印头单元的激光孔径为 6.4  $\mu$ W。

波长：775-800 nm

本机采用会辐射不可见激光束的 3B 类激光二极管。

打印头单元内配备激光二极管和扫描多棱镜。

打印头单元 “不属于现场维修品”：

因此，在任何情况下切勿打开打印头单元。

打印机头单元内的  
激光小孔

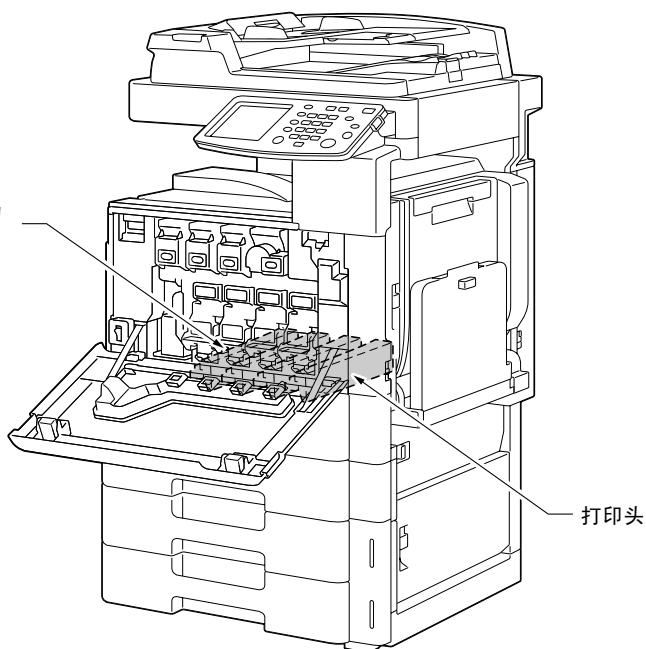

#### CDRH 规定

根据 1990 年颁布的“食品、药物及化妆品法案”，本机经鉴定属于“辐射性能标准”下的 1 类激光产品。对于在美国销售的激光产品，必须申请合格证，并且应报告给“设备与辐射卫生中心”（CDRH），该中心隶属美国“卫生与公共事业部”（DHHS）下辖的“美国食品与药物管理局”。这表示本机不会产生危险激光辐射。

第 x-36 页所示的标签表示符合 CDRH 规定，该标签必须张贴到在美国销售的激光产品上。

---

#### 注意

进行本使用说明书规定以外的控制、调节或操作步骤可能会受到危险的照射。

本机激光器属于半导体激光器。激光二极管的最大功率为 15 mW，波长为 770-800 nm。

#### 供欧洲用户

---

#### CAUTION

Use of controls, adjustments or performance of procedures other than those specified in this manual may result in hazardous radiation exposure.

This is a semiconductor laser. The maximum power of the laser diode is 15 mW and the wavelength is 770-800 nm.

#### 供丹麦用户

---

#### ADVARSEL

Usynlig laserstråling ved åbning, når sikkerhedsafbrydere er ude af funktion. Undgå udsættelse for stråling. Klasse 1 laser produkt der opfylder IEC60825 sikkerheds kravene.

Dansk: Dette er en halvlederlaser. Laserdiodens højeste styrke er 15 mW og bølgelængden er 770-800 nm.

#### 供芬兰、瑞典用户

---

LOUKAN 1 LASERLAITE  
KLASS 1 LASER APPARAT

---

#### VAROITUS!

Laitteen Käyttäminen muulla kuin tässä käyttöohjeessa mainitulla tavalla saattaa altistaa käyttäjän turvallisuusluokan 1 ylittävälle näkyvättömälle la-sersäteilylle.

Tämä on puolijohdelaser. Laserdiodin suurin teho on 15 mW ja aallonpituus on 770-800 nm.

---

**VARNING!**

Om apparaten används på annat sätt än i denna bruksanvisning specificerats, kan användaren utsättas för osynlig laserstrålning, som överskrider gränsen för laserklass 1.

Det här är en halvledarlaser. Den maximala effekten för laserdioden är 15 mW och våglängden är 770-800 nm.

---

**VARO!**

Avattaessa ja suojalukitus ohitettaessa olet alttiina näkymättömälle lasersäteilylle. Älä katso säteeseen.

---

**VARNING!**

Osynlig laserstrålning när denna del är öppnad och spärren är urkopplad. Betrakta ej strålen.

供挪威用户

---

**ADVARSEL**

Dersom apparatet brukes på annen måte enn spesifisert i denne bruksanvisning, kan brukeren utsettes for usynlig laserstråling som overskrider grensen for laser klass 1.

Dette en halvleder laser. Maksimal effekt till laserdiode er 15 mW og bølge-lengde er 770-800 nm.

## 激光安全标签

激光安全标签附在机器外部，如下所示。

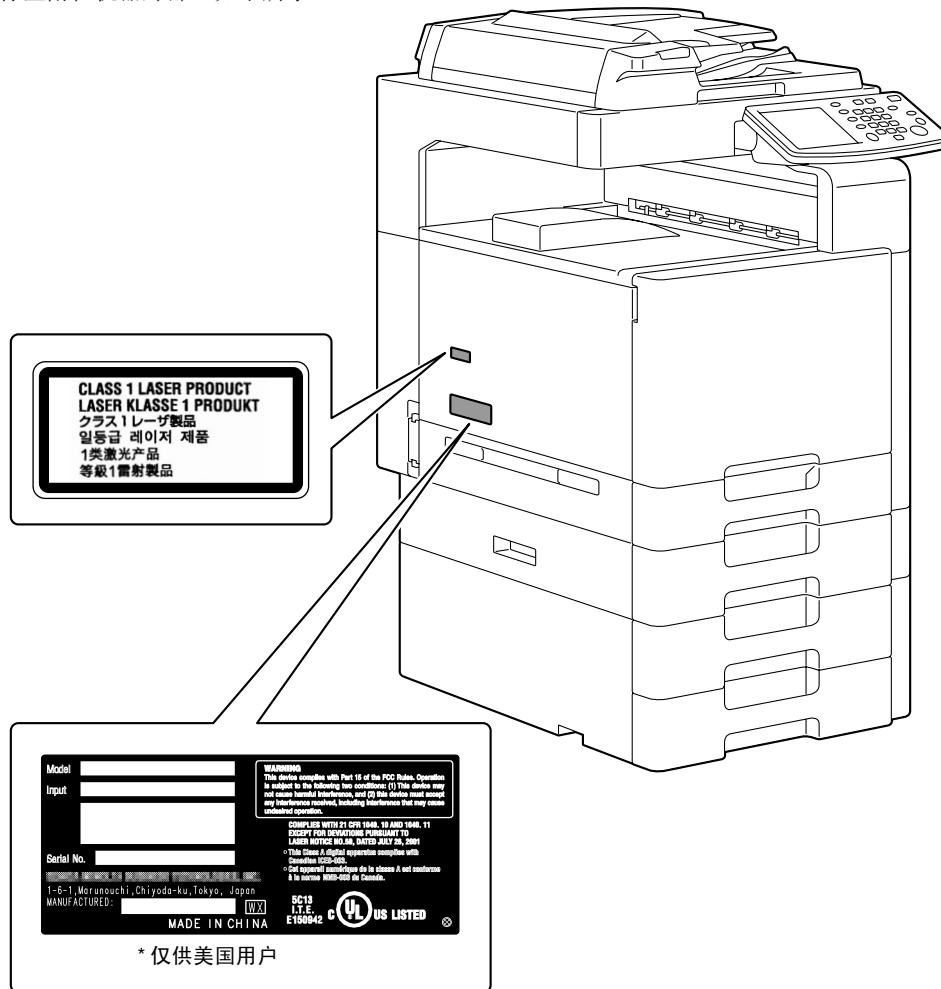

## 臭氧排放

将机器放在通风良好的房间内

正常使用本机的过程中，会产生微量臭氧。但是，如果本机在通风不良的房间内长时间运转，可能会产生令人不快的异味。为了营造舒适、健康和安全的操作环境，建议将安装使用该机器的房间保持良好的通风。

Placer l'appareil dans une pièce largement ventilée

Une quantité d'ozone négligable est dégagée pendant le fonctionnement de l'appareil quand celui-ci est utilisé normalement. Cependant, une odeur désagréable peut être ressentie dans les pièces dont l'aération est insuffisante et lorsque une utilisation prolongée de l'appareil est effectuée. Pour avoir la certitude de travailler dans un environnement réunissant des conditions de confort, santé et de sécurité, il est préférable de bien aérer la pièce où se trouve l'appareil.

## Acoustic noise (for European users only)

Maschinenlärminformations-Verordnung 3. GPSGV: Der höchste Schalldruckpegel beträgt 70 dB(A) oder weniger gemäss EN ISO 7779.

## Notification for US only

Contains Mercury in the LCD control panel backlighting lamp, and/or in the scanning unit lamp. Dispose According to Local, State or Federal Laws.

## Notification for California Customers

This product uses a CR Lithium Battery which contains perchlorate material.

This perchlorate warning applies to perchlorate-containing lithium batteries sold or distributed in California, USA.

"Perchlorate Material - Special handling may apply, See [www.dtsc.ca.gov/hazardouswaste/perchlorate](http://www.dtsc.ca.gov/hazardouswaste/perchlorate)."

## Recycling batteries ( For Taiwan Users Only )

根據地方規定處理使用的電池。



### For EU member states only

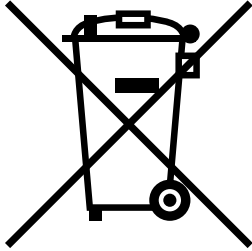

This symbol means: Do not dispose of this product together with your household waste!

Please refer to the information of your local community or contact our dealers regarding the proper handling of end-of-life electric and electronic equipments. Recycling of this product will help to conserve natural resources and prevent potential negative consequences for the environment and human health caused by inappropriate waste handling.



### For EU member states only

This product complies with RoHS (2002/95/EC) Directive.

This device is not intended for use at a video workstation in compliance with BildscharbV.

Das Gerät ist nicht für die Benutzung am Bildschirmarbeitsplatz gemäß BildscharbV vorgesehen.

# 安全警告注意事项和标签

安全警告注意事项和标签出现在本机的下列位置上。  
注意不要在进行像清除卡纸的操作时发生意外事故。

**TONER** Net Wt. 465g (16.4oz)  
BLACK / SCHWARZ Toner made in Japan  
NOIR / ブラック Assembled in China  
JSP-Label A0D7156100

⚠ <b>WARNING</b>	⚠ <b>ATTENTION</b>	🚫
⚠ <b>WARNUNG</b>	⚠ <b>警告</b>	
⚠ <b>ATENCIÓN</b>	⚠ <b>경고</b>	
⚠ <b>AVISO</b>	⚠ <b>اخطار</b>	

**警告**  
切勿燃烧废碳粉盒。  
从火中飞溅出的碳粉  
很危险。

Legal Restrictions on Copying  
Certain types of documents shall never be copied by this copier for the purpose or with the intent to pass copies of such documents other than the original. The following is not a complete list but is meant to be used as a guide to responsive copying.

Financial Instruments	Legal Documents	General
Financial Checks	Wills	Identification Cards, Badges, or Signings
Insurance Policies	Notarized Documents (such as contracts)	Government Documents
Medical Records	Patents	Patents of Copyright
Real Estate Documents	Securities Documents	Records of Government Proceedings
Securities Documents	Trade Secrets	Records of Proceedings of a Court of Law
Securities Documents	Trade Secrets	Records of Proceedings of a Court of Law
Securities Documents	Trade Secrets	Records of Proceedings of a Court of Law

**注意**  
复制某些类型的文档是  
非法的。切勿复制这些  
文档。

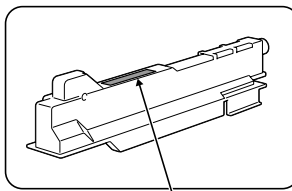
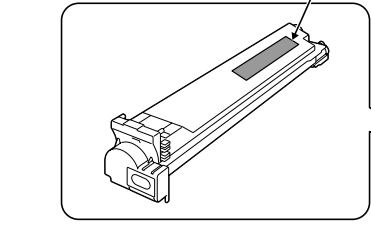
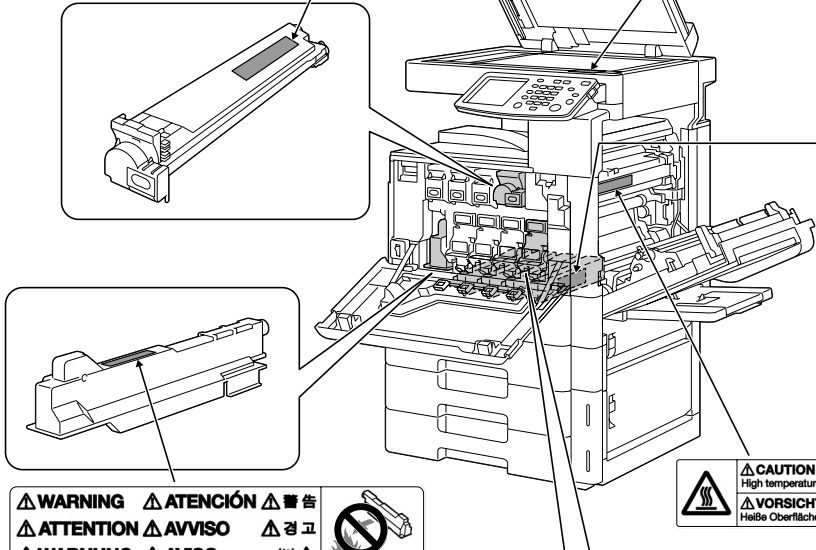

⚠ <b>CAUTION</b>	⚠ <b>ATTENTION</b>	⚠ <b>PRECAUCIÓN</b>	⚠ <b>注意</b>	⚠ <b>注意</b>
⚠ <b>VORSICHT</b>	⚠ <b>ADVERTENCIA</b>	⚠ <b>ATTENTION</b>	⚠ <b>注意</b>	⚠ <b>注意</b>
⚠ <b>AVVERTIMENTO</b>	⚠ <b>ATTENTION</b>	⚠ <b>ATTENTION</b>	⚠ <b>注意</b>	⚠ <b>注意</b>
⚠ <b>AVVERTIMENTO</b>	⚠ <b>ATTENTION</b>	⚠ <b>ATTENTION</b>	⚠ <b>注意</b>	⚠ <b>注意</b>

**注意**  
切勿改动或取下安装在  
本机上的任一盖板或面  
板，否则可能会使您暴  
露于激光辐射下。

⚠ <b>WARNING</b>	⚠ <b>ATENCIÓN</b>	⚠ <b>警告</b>	🚫
⚠ <b>ATTENTION</b>	⚠ <b>AVISO</b>	⚠ <b>경고</b>	
⚠ <b>WARNUNG</b>	⚠ <b>AVISO</b>	⚠ <b>اخطار</b>	
⚠ <b>警告</b>	⚠ <b>警告</b>	⚠ <b>警告</b>	

**警告**  
请勿将废碳粉盒竖直或倾  
斜放置于末端，否则碳粉  
可能会飞溅。

**注意**  
切勿燃烧废碳粉盒。  
从火中飞溅出的碳粉很  
危险。

⚠ <b>CAUTION</b>	⚠ <b>ATTENTION</b>	⚠ <b>PRECAUCIÓN</b>	⚠ <b>注意</b>	⚠ <b>注意</b>
⚠ <b>VORSICHT</b>	⚠ <b>ADVERTENCIA</b>	⚠ <b>ATTENTION</b>	⚠ <b>注意</b>	⚠ <b>注意</b>
⚠ <b>AVVERTIMENTO</b>	⚠ <b>ATTENTION</b>	⚠ <b>ATTENTION</b>	⚠ <b>注意</b>	⚠ <b>注意</b>
⚠ <b>AVVERTIMENTO</b>	⚠ <b>ATTENTION</b>	⚠ <b>ATTENTION</b>	⚠ <b>注意</b>	⚠ <b>注意</b>

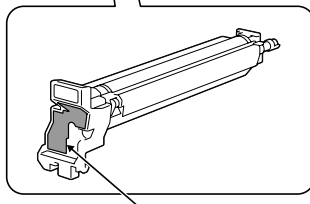

**注意**  
定影单元周围的部分非常  
烫。触摸没有标示的  
任何部分都可能引起灼  
伤。

**警告**  
切勿燃烧旧成像单元。  
从火中飞溅出的碳粉很  
危险。

**提醒**

请勿取下注意标志与标签。如果注意标志与标签被弄脏，请清洁使其清晰。如果没有使注意标志与标签清晰，或如果损坏了注意标志与标签，请联系维修人员。



---

## 用户特殊注意事项

供加拿大用户

NOTICE:

This product meets the applicable Industry Canada technical specifications.

The Ringer Equivalence Number is an indication of the maximum number of devices allowed to be connected to a telephone interface. The termination on an interface may consist of any combination of devices subject only to the requirement that the sum of the RENs of all the devices does not exceed five.

AVIS:

Le present materiel est conforme aux specifications techniques applicables d'Industrie Canada.

L'indice d'equivalence de la sonnerie (IES) sert a indiquer le nombre maximal de terminaux qui peuvent etre raccordes a une interface telephonique. La terminaison d'une interface peut consister en une combinaison quelconque de dispositifs, a la seule condition que la somme d'indices d'equivalence de la sonnerie de tous les dispositifs n'excede pas 5.

供美国用户

FCC PART 68 REQUIREMENTS:

This equipment complies with Part 68 of the FCC rules and the requirements adopted by the ACTA. On the cover of this equipment is a label that contains, among other information, a product identifier in the format US:AAAEQ##TXXXX. If required, this information must be provided to the telephone company.

This equipment uses certification jack USOC RJ11C.

A plug and jack used to connect this equipment to the premises wiring and telephone network must comply with the applicable FCC Part 68 rules and requirements adopted by the ACTA.

A compliant telephone cord and modular plug is provided with this product. It is designed to be connected to a compatible modular jack that is also compliant. See installation instructions for details.

The REN is used to determine the number of devices that may be connected to a telephone line. Excessive RENs on a telephone line may result in the devices not ringing in response to an incoming call. In most but not all areas, the sum of RENs should not exceed five (5.0).

To be certain of the number of devices that may be connected to a line, as determined by the total RENs, contact the local telephone company For products approved after July 23, 2001, the REN for this product is part of the product identifier that has the format US: US:AAAEQ##TXXXX.. The digits represented by ## are the REN without a decimal point (e.g., 03 is a REN of 0.3). For earlier products, the REN is separately shown on the label.

If this equipment FK-507 and ML-504 causes harm to the telephone network, the telephone company will notify you in advance that temporary discontinuance of service may be required. But if advance notice isn't practical, the telephone company will notify the customer as soon as possible. Also, you will be advised of your right to file a complaint with the FCC if you believe it is necessary.

The telephone company may make changes in its facilities, equipment, operations or procedures that could affect the operation of the equipment. If this happens the telephone company will provide advance notice in order for you to make necessary modifications to maintain uninterrupted service.

If trouble is experienced with this equipment FK-507 and ML-504 , for repair or warranty information, please contact the Konica Minolta dealer location where you purchased this equipment. If the equipment is causing harm to the telephone network, the telephone company may request that you disconnect the equipment until the problem is resolved.

Connection to party line service is subject to state tariffs. Contact the state public utility commission, public service commission or corporation commission for information. If your home has specially wired alarm equipment connected to the telephone line, ensure the installation of FK-507 and ML-504 does not disable your alarm equipment. If you have questions about what will disable alarm equipment, consult your telephone company or a qualified installer.

The Telephone Consumer Protection Act of 1991 makes it unlawful for any person to use a computer or other electronic device, including FAX machines, to send any message unless such message clearly contains in a margin at the top or bottom of each transmitted page or on the first page of the transmission, the date and time it is sent and an identification of the business or other entity, or other individual sending the message and the telephone number of the sending machine or such business, other entity, or individual. (The telephone number provided may not be a 900 number or any other number for which charges exceed local or long-distance transmission charges.)

In order to program this information into your FAX machine, you should complete the following steps: See chapter 9.6, "Fax Settings", of the User's Guide [Network Scan/Fax/Network Fax Operations].

---

WARNING/CAUTION Explained

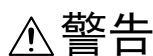

The exclamation point within an equilateral triangle followed by the word "Warning" is intended to alert the user to the possibility that a disregard for the warning may result in fatal hazards or critical injuries. Be sure to focus your attention on the Warning headings when reading this Quick Guide.

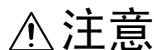

The exclamation point within an equilateral triangle followed by the word "Caution" is intended to alert the user to the possibility that a disregard for the caution may result in minor injuries or in physical damage. Be sure to focus your attention on the Caution headings when reading this Quick Guide.

---

#### 供新西兰用户

This device is equipped with pulse dialing while the Telecom standard is DTMF tone dialing. There is no guarantee that Telecom lines will always continue to support pulse dialing.

Use of pulse dialing, when this equipment is connected to the same line as other equipment, may give rise to bell tinkle or noise and may also cause a false answer condition. Should such problems occur, the user should not contact the Telecom Fault Service.

This equipment may not provide for the effective hand-over of a call to another device connected to the same line.

This equipment does not fully meet Telecom's impedance requirements. Performance limitations may occur when used in conjunction with some parts of the network. Telecom will accept no responsibility should difficulties arise in such circumstances.

The grant of a Telepermit for any item of terminal equipment indicates only that Telecom has accepted that the item complies with minimum conditions for connection to its network. It indicates no endorsement of the product by Telecom, nor does it provide any sort of warranty. Above all, it provides no assurance that any item will work correctly in all respects with another item of Telepermitted equipment of a different make or model, nor does it imply that any product is compatible with all of Telecom's network services.

The automatic calling functions of this equipment must not be used to cause a nuisance to other customers.

Telepermitted equipment only may be connected to the auxiliary telephone port. The auxiliary port is not specifically designed for 3-wire connected equipment. 3-wire might not respond to incoming ringing when connected to this port.

---

供欧洲用户

The Facsimile has been approved in accordance with Council Decision 1999/5/ EC for pan-European single terminal connection to the public switched telephone network (PSTN). However, due to differences between the individual PSTNs provided in different countries, the approval does not, of itself, give an unconditional assurance of successful operation on every PSTN network terminal point.

In the event of problems, you should contact your equipment supplier in the first instance.



The CE marking must be affixed to the product or to its data plate. Additionally it must be affixed to the packaging, if any, and to the accompanying documents.

## 空间要求

为了确保可以轻松进行机器操作、耗材补充、零件更换以及定期维修，请遵守下述详细建议的空间要求。

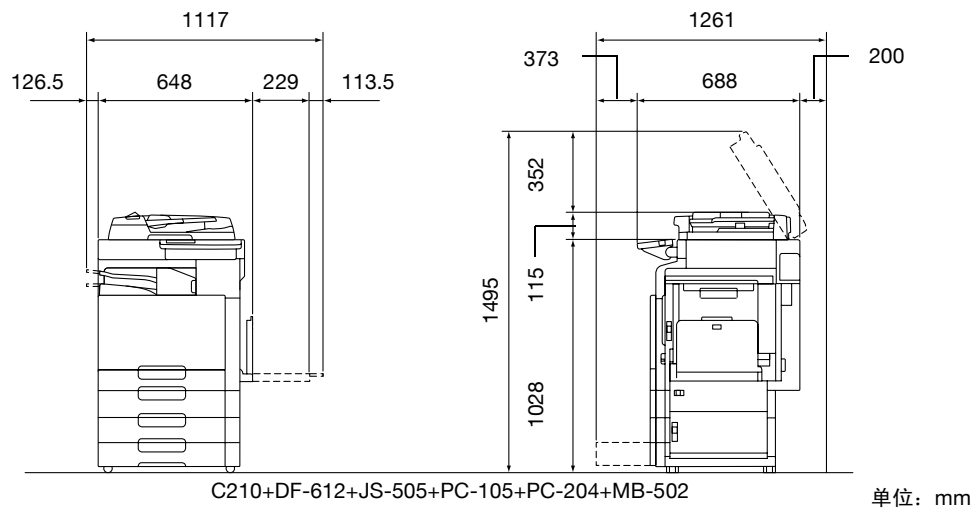

### 提醒

未安装选购件时，请务必在本机后部保留 200 mm 或更大的间隙用于铺设通风管道。

---

## 操作注意事项

为了保证本机的最佳性能，请遵守下述注意事项。

### 电源

电源要求如下：

- 电压波动：最大± 10%（220 到 240V AC 时）
- 频率波动：最大± 3 Hz（50 Hz/60 Hz 时）
- 尽可能使用电压或电流波动较小的电源。

### 操作环境

正确操作机器的环境要求如下。

- 温度：10 °C 到 30 °C，每小时波动范围在 10 °C 内
- 湿度：15% 到 85%，每小时波动范围在 10% 内

### 复印件的存储

若要存储复印件，请按照下列建议。

- 需要长时间保存的复印件应保存在不暴露在光线的地方，以防止褪色。
- 含有溶剂的粘合剂（例如，喷洒胶）可能会将复印件上的碳粉溶解。
- 彩色复印件上的碳粉层比普通黑白复印件要厚一些。因此，折叠彩色复印件时，折痕上的碳粉可能会脱落。

## 关于复印的法律限制

复印特定类型的文件时，不得将此类文件的复印件用于原稿一样的目的或意图。

下表所列项目尚不完备，但对于负责任的复印者，可以将其用作参考。

### < 财务文件 >

- 个人支票
- 旅行支票
- 汇票
- 存款单
- 债券或其它借据
- 证券

### < 法律文件 >

- 粮票
- 邮票（已盖戳或未盖戳的）
- 政府机构开具的支票或汇票
- 国内印花税票（已盖戳或未盖戳的）
- 护照
- 移民证
- 机动车牌照和驾驶证
- 房屋与地产的产权证和转让证

### < 一般文件 >

- 身份证、胸卡或徽章
- 未经版权所有者授权的版权保护作品

此外，在任何情况下均严禁复印本国货币或外国货币，或在未经版权所有者授权的情形下复印艺术作品。

如果对文件性质存在疑问，请咨询法律顾问。



#### 细节

为防止非法复制某些文件，如纸张货币，本机具有防伪功能。

由于本机具有防伪功能，图像可能会失真。

## 使用说明书的介绍

本机的使用说明书包括本书和使用说明书 CD。

本使用说明书以书籍形式提供，包含了可让您立即操作本机的说明。有关功能或维修操作的详细说明，请参见使用说明书 CD 上的使用说明书。

### 说明书介绍

#### 快速指南 [复印 / 打印 / 传真 / 扫描操作]

本快速指南包含最常用功能的操作步骤和说明，可以立即使用本机。

此外，本快速指南包含有关安全使用本机的备注和注意事项。

务必在使用本机前阅读本说明书。

### 使用说明书 CD 的介绍

使用说明书 CD 附带在本机中。在初始画面中，选择要查看的使用说明书，然后检查各种功能的详细资料。



#### 使用说明书 [复印操作]

本使用说明书包括复印模式操作和本机维护的说明。

有关纸张与原稿、使用方便应用功能复印、更换耗材和故障排除操作（例如清除卡纸）的详细资料，请参见本使用说明书。

#### 使用说明书 [打印操作]

本使用说明书包括用标准内置打印机控制器指定的打印功能的详细资料。

有关使用打印机功能操作步骤的详细资料，请参见本使用说明书。

#### 使用说明书 [网络扫描 / 传真 / 网络传真操作]

本使用说明书包含了网络扫描、G3 传真和网络传真操作的详细资料。

有关通过电子邮件、G3 传真、Internet 传真、IP 地址传真和 IP 中继操作使用网络扫描的步骤，请参见本说明书。

要使用 G3 传真、Internet 传真、IP 地址传真和 IP 中继功能，必须单独购买选购的传真组件。

#### 使用说明书 [传真驱动程序操作]

本使用说明书包含了可用来直接从计算机发送传真的传真驱动程序功能的详细信息。

有关使用 PC- 传真功能的操作步骤，请参见本使用说明书。

要使用传真功能，必须单独购买选购的传真组件。

#### 使用说明书 [网络管理员]

本使用说明书包含了指定用于连接和在网络下使用本机的设置，更改软件开关设置，以及使用 Assistant tool 的详细资料。

有关网络设置、软件开关设置和 Assistant tool 的说明，请参见本使用说明书。

### 商标 / 版权所有

本说明书包含有关商标和版权所有的详细资料。

务必在使用本机前阅读本说明书。

### 如何打开使用说明书光盘主菜单

在 Windows 系统中，将光盘插入计算机的 CD 驱动器，主菜单便会自动显示。

在 Macintosh OS9/OSX 系统中，双击桌面上的光盘图标，再双击 index\_mac 打开主菜单。



#### 备注

查看这些使用说明书需要 Adobe Reader。



## 可用功能

bizhub C210 是一款数码彩色多功能复合机，可减少工作流程并满足多种应用或办公环境。除了任何公司中最重要的复印、传真、扫描和打印功能，本机还具有网络功能支持更有效的文档管理。



## 复印操作

能以高速打印高质量复印件。可制作出鲜艳色彩、黑白或其它单色复印件以满足任何需求。许多应用功能可大大降低办公成本并提高效率。

## 打印操作

从计算机打印时，可以指定各种设置，例如纸张尺寸、图像质量、色调和布局。使用机密打印功能，可以用密码保护重要文档的打印。可以从附带的光盘轻松安装打印机驱动程序。

## 传真操作

使用本机不仅可以扫描原稿，也可以将计算机数据发送传真。可以将一份传真同时发送到多个目的地，并且也可以转发已接收的传真。



...

### 备注

要使用传真功能，必须安装选购的传真组件FK-507。

## 网络操作

可以通过网络连接进行打印。使用本机扫描的数据可以轻松通过网络传送。通过使用控制面板指定目的地，可以将数据传送到FTP服务器或其他网络计算机，也可以将其作为电子邮件附件发送，或使用因特网发送传真。



...

### 备注

要使用Internet传真功能、IP地址传真功能和IP中继功能，必须安装选购的传真组件FK-507。

## 扫描操作

纸张文件可以快速转换为数字数据。这种转换的数据可方便地通过网络传送。此外，使用各种TWAIN兼容应用程序可以将本机用作扫描器。

## 控制面板

控制面板包括触摸面板（可用来指定各种功能设置）和各种按键，如 [开始] 键和 [停止] 键的设置。可以使用这些键执行的操作如下所述。

在本说明书中，[ ] 表示控制面板上的按键以及触摸面板上的按钮。

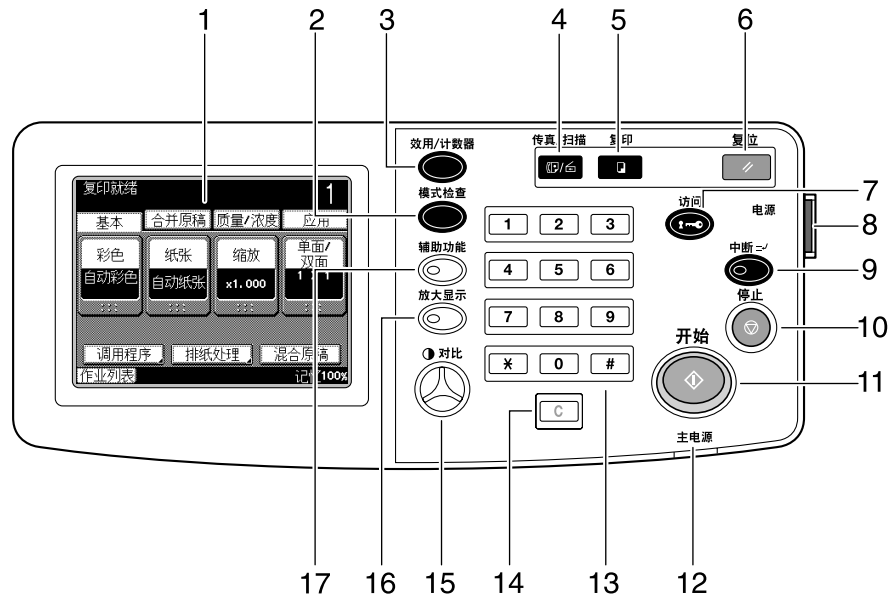

号码	零件名称	说明
1	触摸面板	显示各种屏幕与信息。 直接触摸面板以指定各种设置。
2	[模式检查] 键	按此键来检查各种设置。
3	[效用 / 计数器] 键	按此键以显示效用屏幕和用量计数器屏幕。
4	[传真 / 扫描] 键	按此键进入传真 / 扫描模式。 当机器处于传真 / 扫描模式时，[传真 / 扫描] 键上的指示灯会发绿光。
5	[复印] 键	按此键进入复印模式。（作为默认值，机器处于复印模式。） 当机器处于复印模式时，[复印] 键上的指示灯会发绿光。
6	[复位] 键	按此键以清除所有在控制面板与触摸面板上输入的设置（编程设置除外）。
7	[访问] 键	应用了账户跟踪设置时，输入账户名和密码后按此键登录到注册的账户，或者从账户注销。
8	副电源开关	按此键打开 / 关闭机器操作。关闭后，机器进入节能状态。
9	[中断] 键	按此键可以进入中断模式。当机器处于中断模式时，[中断] 键上的指示灯会亮起绿光，且触摸面板上出现“现在处于中断模式”信息。要取消中断模式，请再按一次 [中断] 键。
10	[停止] 键	复印时按此键将停止操作。正执行的复印作业被删除。 如果在扫描或拨号过程中按下了 [停止] 键，则会出现请求确认删除作业的屏幕。在确认屏幕中，选择要删除的作业。
11	[开始] 键	按此键开始复印、扫描或传真操作。当本机准备开始操作时，[开始] 键上的指示灯会亮起蓝光。如果 [开始] 键上的指示灯亮起橙光，则不能开始操作。 按此键以重新开始被停止的作业。
12	主电源指示灯	当用主电源开关打开本机时亮起绿光。
13	数字键盘	用于输入需要制作的份数。 用于输入缩放比率。 用于输入各种设置。
14	[C]（清除）键	按本键以删除用数字键盘输入的数值（例如份数、缩放比率或尺寸）。
15	[对比] 旋钮	用于调整触摸面板的对比度。
16	[放大显示] 键	按本键进入放大显示方式。
17	[辅助功能] 键	按此键以显示用于指定用户操作设置功能设置的屏幕。



### 备注

有关详细资料，请参见使用说明书 [复印操作] 的第 1 章“开始复印之前”。

## 打开 / 关闭机器电源

本机具有两种电源控制：主电源开关和副电源开关。

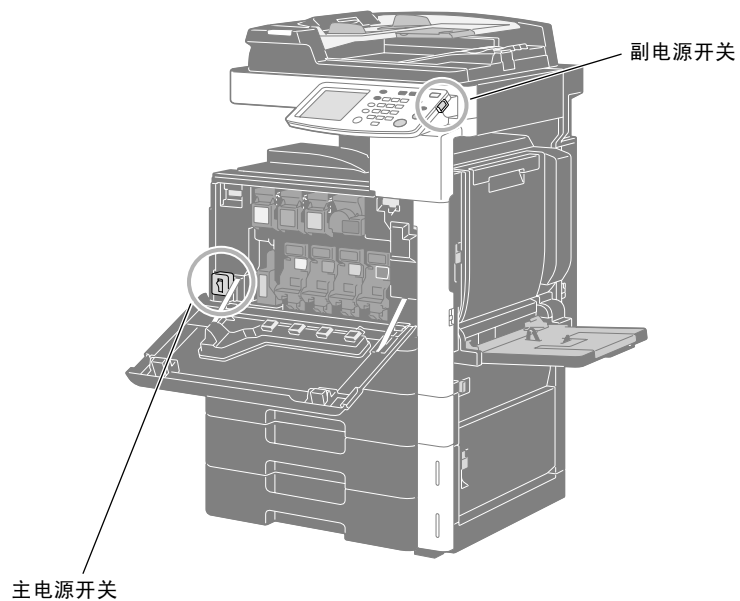

### 主电源开关

该开关可打开 / 关闭机器的所有功能。通常情况下主电源开关打开。

### 副电源开关

按此键打开 / 关闭机器操作。关闭后，机器进入节能状态。

### 打开机器电源

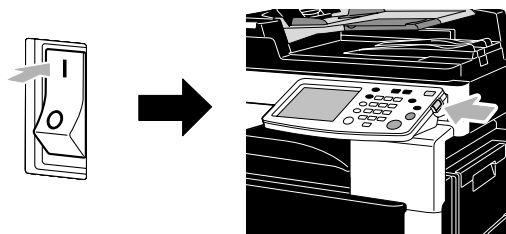

### 关闭机器电源

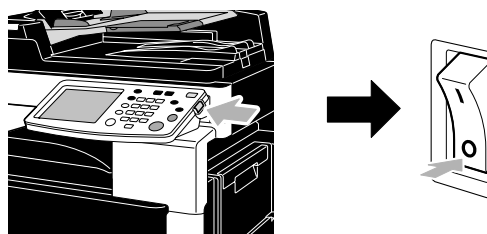



#### 细节

关机后再打开机器时，请在关闭后等待至少 10 秒钟再打开机器。如果关机后在很短时间内开机，本机可能工作不正常。

本机正在打印时请不要关闭，否则可能会发生卡纸。

本机正在运行时请不要关闭，否则正在扫描或传送或排队作业的数据可能会被删除。



...

#### 备注

有关详细资料，请参见使用说明书 [复印操作] 的第 1 章“开始复印之前”。

## 装入纸张

按照下述步骤将纸张装入各种纸盒。

### 将纸张装入纸盒 1

按照下述步骤将纸张装入纸盒 1。

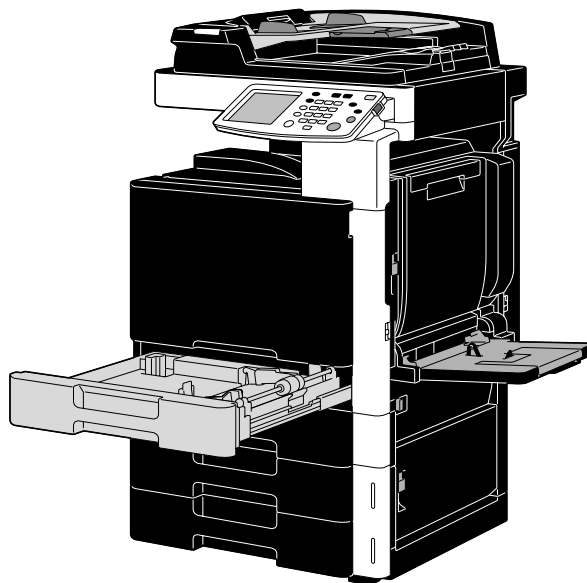

- 1 将横向导板滑动到适合要装入的纸张尺寸的位置。

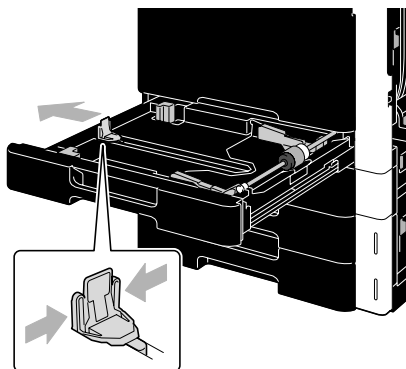

- 对于大于 A3 尺寸的纸张  
装入大于 A3 尺寸的纸张时，请如图所示调整导板。

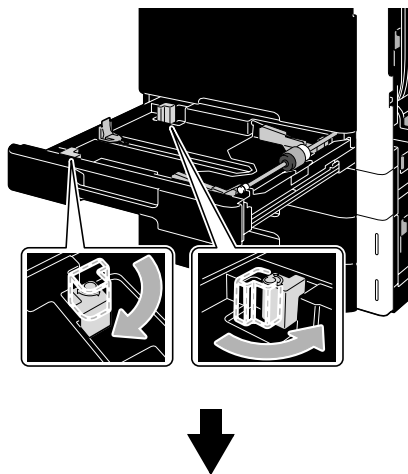

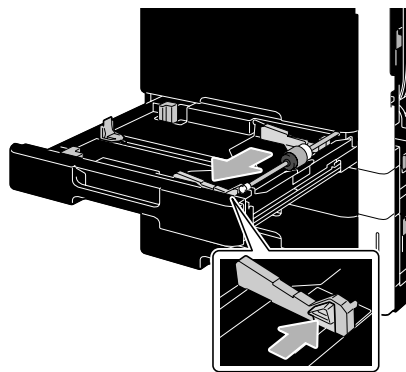
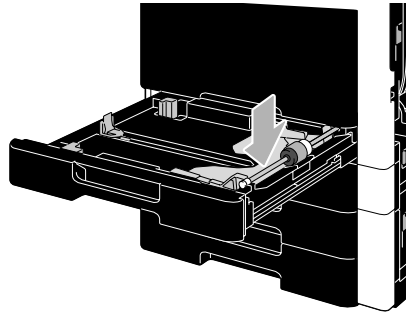

**2** 在纸盒中装入纸张。

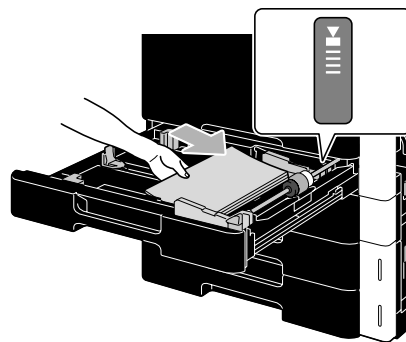

- 装入纸张，使要打印的一面朝上。
- 装入多页纸张时，纸堆的顶部不得超过 ▼ 标记。
- 最多可以装入 250 张普通纸。

3 在触摸面板中，选择纸张类型。



- 按 [↑] 和 [↓] 直到出现需要的纸张类型。
- 如果装入标签纸，选择“厚纸1”。
- 如果装入非标准尺寸纸张，请指定纸张尺寸设置。
- 有关指定纸张尺寸和纸张类型设置的详细资料，请参见使用说明书 [复印操作] 的第6章“复印纸/原稿”。
- 在 OHP 胶片上只可用黑色打印。



细节

纸盒1 中可装入下列类型和数量的纸张。

普通纸 (60 g/m<sup>2</sup> 到 90 g/m<sup>2</sup>): 最多 250 张  
厚纸1 (91 g/m<sup>2</sup> 到 150 g/m<sup>2</sup>): 最多 20 张  
厚纸2 (151 g/m<sup>2</sup> 到 209 g/m<sup>2</sup>): 最多 20 张  
厚纸3 (210 g/m<sup>2</sup> 到 256 g/m<sup>2</sup>): 最多 20 张

OHP 胶片: 最多 20 张

信封: 最多 20 个

标签纸: 最多 20 张

纸盒1 可指定下列尺寸的纸张。

标准尺寸纸张: A3 到 B6 、A6 、12-1/4 × 18 \*<sup>1</sup>、12 × 18 \*<sup>1</sup> 到 5-1/2 × 8-1/2 / 、4 × 6   
8 × 13 \*<sup>2</sup>、16K / 、8K

非标准尺寸纸张: 宽度: 90.0 mm 到 311.1 mm ; 长度: 139.7 mm 到 457.2 mm

\*<sup>1</sup> 这是大于 A3 的尺寸。12-1/4 × 18 相当于 311.1 mm × 457.2 mm，12 × 18 相当于 304.8 mm × 457.2 mm。

\*<sup>2</sup> 有 5 种 Foolscap 尺寸: 220 × 330 mm 、8-1/2 × 13 、8-1/4 × 13 、8-1/8 × 13-1/4 和 8 × 13 。  
可以选择这些尺寸中的任何一个。有关详细资料，请与维修人员联系。



备注

有关详细资料，请参见使用说明书 [复印操作] 的第1章“开始复印之前”。



## 将纸张装入纸盒 2/3/4

按照下述步骤将纸张装入纸盒 2、纸盒 3 和纸盒 4。纸盒 2、3 和 4 是选购件。

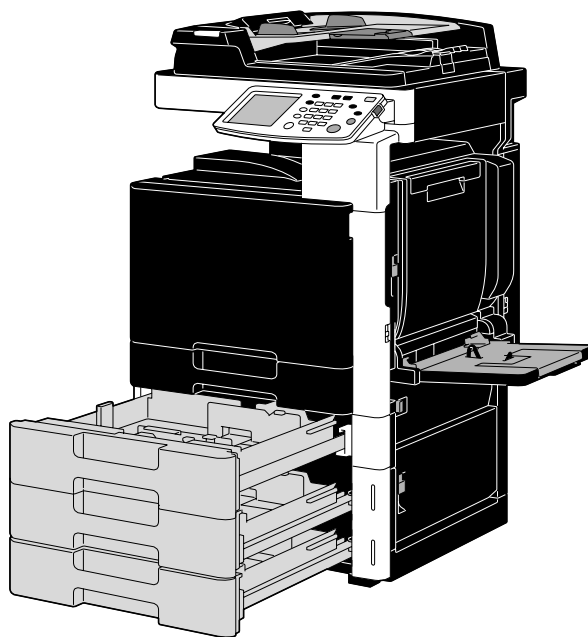

- 1 将横向导板滑动到适合要装入的纸张尺寸的位置。

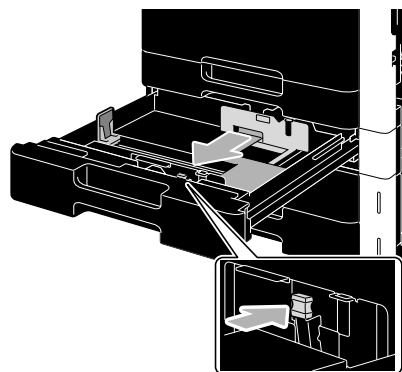
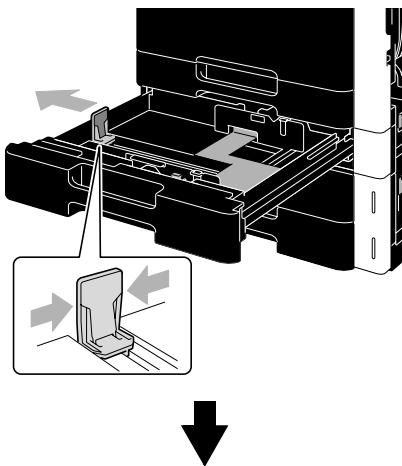

## 2 在纸盒中装入纸张。

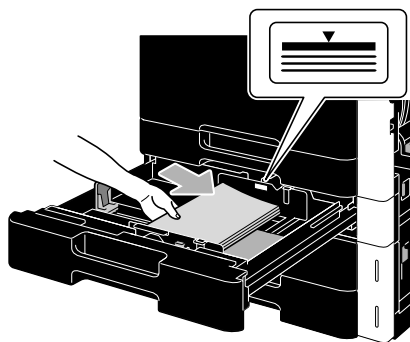

- 装入纸张，使要打印的一面朝上。
- 装入多页纸张时，纸堆的顶部不得超过 ▼ 标记。
- 最多可以装入 500 张普通纸。有关指定可以装入厚纸张数的详细资料，请参见使用说明书 [复印操作] 的第 6 章“复印纸 / 原稿”。



...

### 备注

有关详细资料，请参见使用说明书 [复印操作] 的第 1 章“开始复印之前”。

### 在 LCT 中装入纸张

按照下述步骤将纸张装入 LCT。LCT 是选购件。

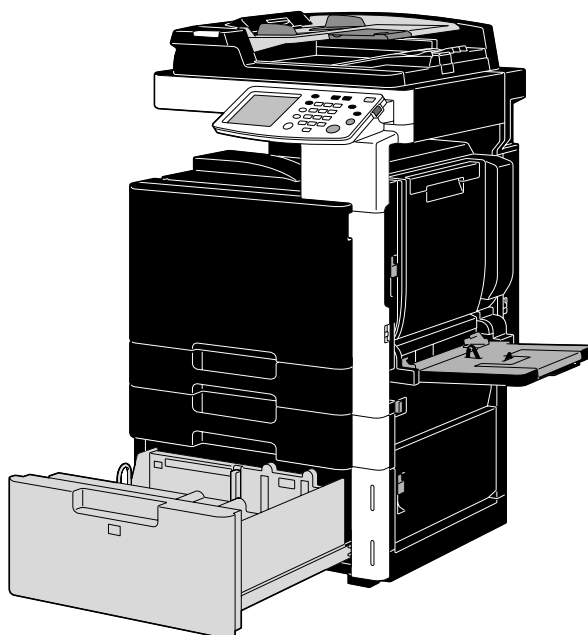

在纸盒中装入纸张。

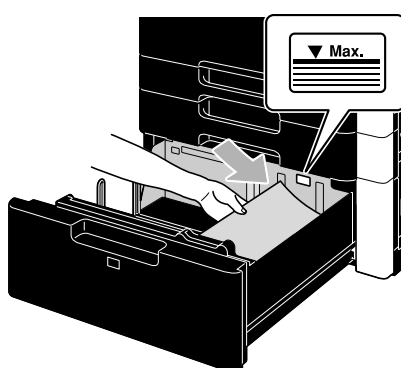
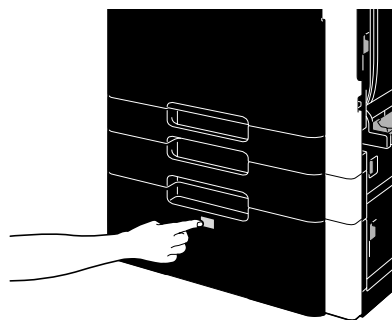

- 按纸盒释放按钮拉出 LCT。
- 装入纸张，使要打印的一面朝上。
- 装入多页纸张时，纸堆的顶部不得超过 ▼ 标记。
- 最多可以装入 2,500 张普通纸。有关指定可以装入厚纸张数的详细资料，请参见使用说明书 [复印操作] 的第 6 章 “复印纸 / 原稿”。



...

**备注**

有关详细资料，请参见使用说明书 [复印操作] 的第 1 章 “开始复印之前”。

## 将纸张装入手送进纸盒

如果想要打印到未装入纸盒中尺寸的纸张，可以通过手送进纸盒手动送纸。手送进纸盒是选购件。按照下述步骤将纸张装入手送进纸盒。

### 1 打开手送进纸盒。

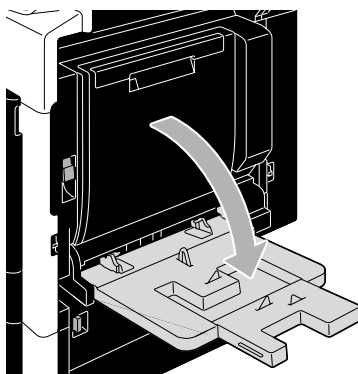

- 装入大尺寸纸张时，拉出纸盒扩展器。

### 2 在纸盒中装入纸张。

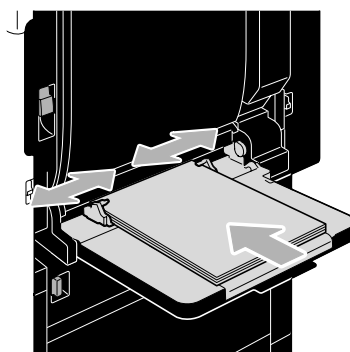

- 装入纸张，使要打印的一侧朝下。
- 装入多页纸张时，纸堆的顶部不得超过 ▼ 标记。
- 最多可以装入 100 张普通纸。
- 将横向导板滑动到适合要装入的纸张尺寸的位置。

### 3 在触摸面板中，选择纸张类型。



- 按 [↑] 和 [↓] 直到出现需要的纸张类型。
- 如果装入标签纸, 选择“厚纸 1”。
- 如果装入非标准尺寸纸张, 请指定纸张尺寸设置。
- 有关指定纸张尺寸和纸张类型设置的详细资料, 请参见使用说明书 [复印操作] 的第 6 章“复印纸 / 原稿”。
- 在 OHP 胶片上只可用黑色打印。



#### 细节

手送进纸盒中可装入下列类型和数量的纸张。

普通纸 (60 g/m<sup>2</sup> 到 90 g/m<sup>2</sup>): 最多 100 张

厚纸 1 (91 g/m<sup>2</sup> 到 150 g/m<sup>2</sup>): 最多 20 张

厚纸 2 (151 g/m<sup>2</sup> 到 209 g/m<sup>2</sup>): 最多 20 张













厚纸 3 (210 g/m<sup>2</sup> 到 256 g/m<sup>2</sup>): 最多 20 张

OHP 胶片: 最多 20 张

信封: 最多 10 个





标签纸: 最多 20 张

手送进纸盒可指定下列尺寸的纸张。

标准尺寸纸张: A3  到 B6 、A6 、12-1/4 × 18 <sup>\*1</sup>、12 × 18 <sup>\*1</sup> 到 5-1/2 × 8-1/2 、4 × 6   
8 × 13 <sup>\*2</sup>、16K 、8K 

非标准尺寸纸张: 宽度: 90.0 mm 到 311.1 mm ; 长度: 139.7 mm 到 457.2 mm

<sup>\*1</sup> 这是大于 A3 的尺寸。12-1/4 × 18 相当于 311.1 mm × 457.2 mm, 12 × 18 相当于 304.8 mm × 457.2 mm。

<sup>\*2</sup> 有 5 种 Foolscap 尺寸: 220 × 330 mm 、8-1/2 × 13 、8-1/4 × 13 、8-1/8 × 13-1/4  和 8 × 13 。  
可以选择这些尺寸中的任何一个。有关详细资料, 请与维修人员联系。



#### 备注

有关详细资料, 请参见使用说明书 [复印操作] 的第 1 章“开始复印之前”。

## 清除卡纸

如发生卡纸，出现显示卡纸位置的如下所示屏幕之一。若要清除卡纸，请检查屏幕上显示的位置，然后执行必要的操作。

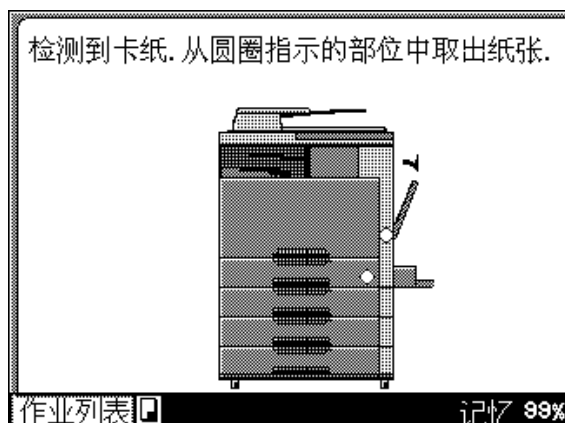

闪烁的“○”指示卡纸位置。

亮起的“○”指示可能发生卡纸、应进行检查的区域。

### 卡纸位置

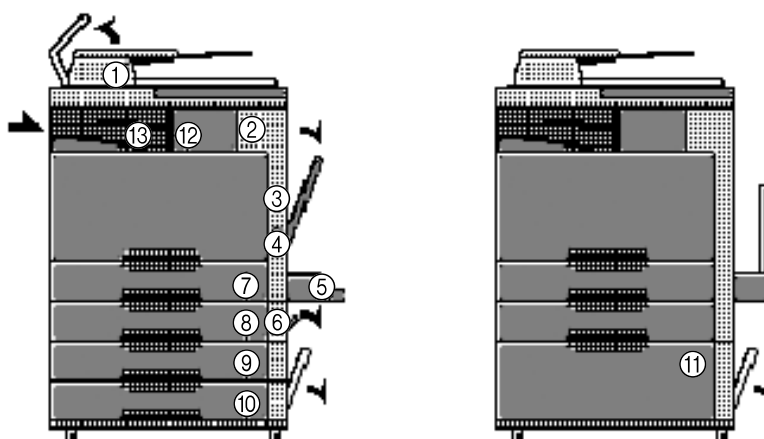

有关卡纸 1 到 11 的详细资料，请参见本说明书上的第 x-61 页并执行适当的操作。

有关卡纸 12 和 13（分离器）的详细资料，请参见本说明书上的第 x-62 页并执行适当的操作。



#### 备注

有关清除卡纸步骤的详细资料，请参见使用说明书 [复印操作] 的第 4 章“故障排除”。

## 清除卡纸（主机）

下列步骤介绍了如何清除在 ADF、右上侧门或纸盒中发生的卡纸。

### ADF

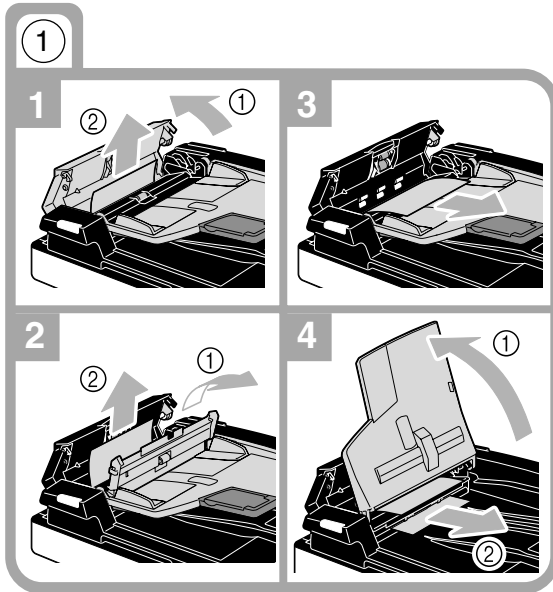

### 右上侧门单元

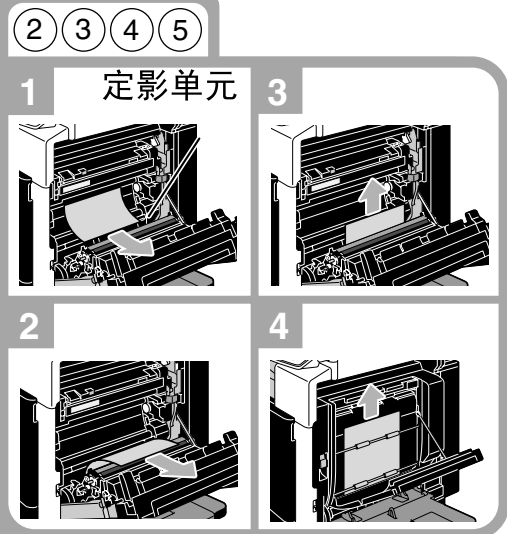

### 纸盒

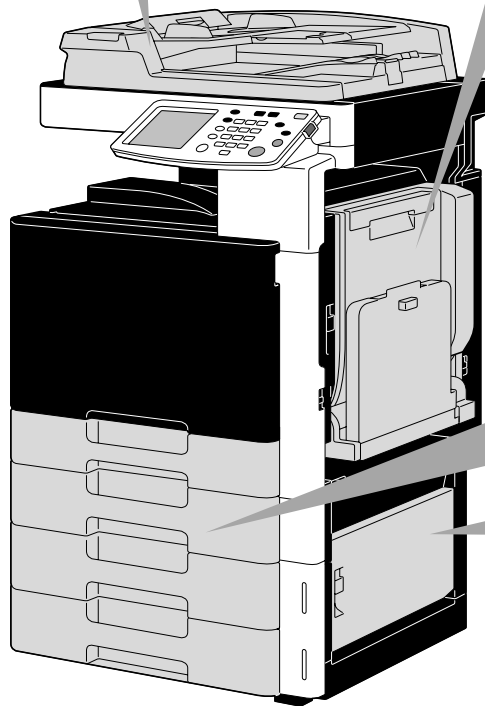
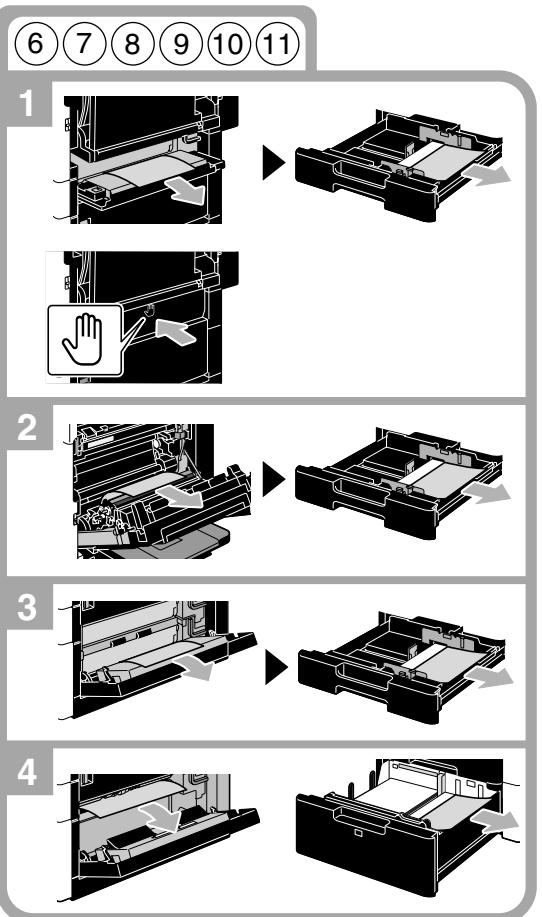

\* 上面的插图表示安装了选购的 ADF、双面器组件、手送进纸盒、附加纸盒纸柜和双纸盒纸柜的主机。

## ⚠ 注意

在定影组件周围的部位会非常烫。

→ 触摸除所示拉杆与旋钮以外的任何部分均可能造成灼伤。如果不慎灼伤，请立即用冷水给皮肤降温，然后到专业医师处就诊。

## ⚠ 注意

碳粉飞溅注意事项。

- 注意不要让碳粉撒落到机器内或沾染到衣服或手上。
- 如果手上沾染了碳粉，请立即用肥皂和水清洗。
- 如果碳粉进入眼睛，请立即用水冲洗，然后到专业医师处就诊。

### 清除卡纸（分离器）

下列步骤介绍了如何清除在分离器中发生的卡纸。

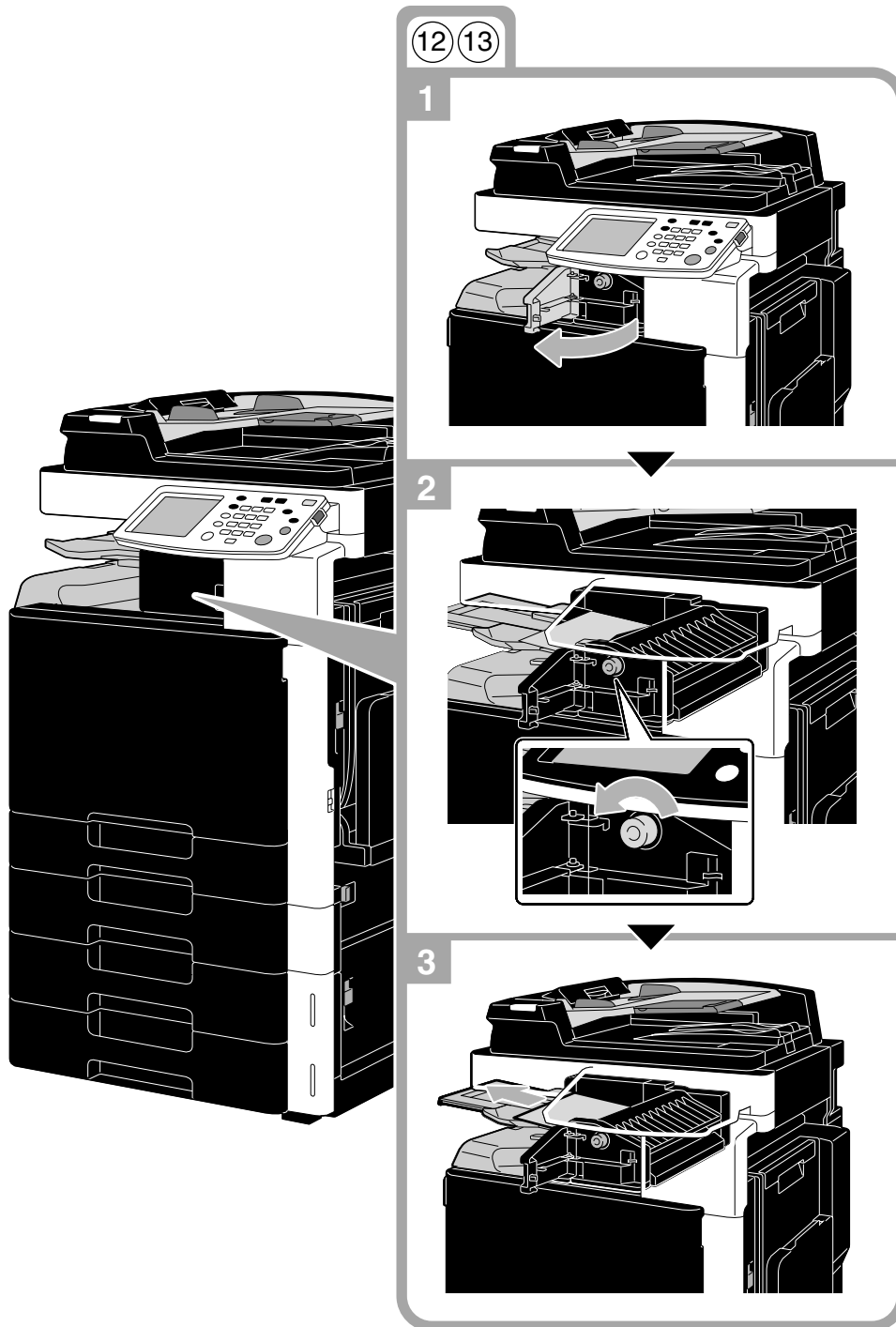



## 更换耗材

需要更换耗材时，例如，碳粉盒已空或者废碳粉盒已满时，则会出现表示应更换的信息。出现这种信息时，请按照相应步骤更换。

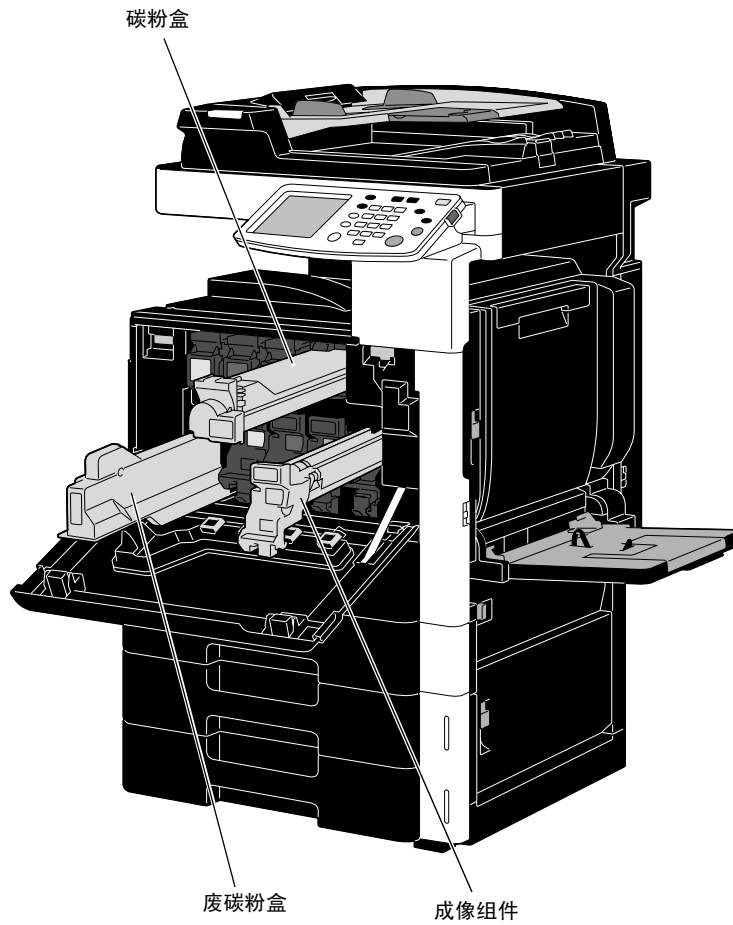

备注

有关详细资料，请参见使用说明书 [复印操作] 的第8章“更换碳粉盒 / 废碳粉盒 / 成像组件”。

当碳粉快用完时，会出现下列信息（如果由用户更换）。



细节

有关更换步骤的详细资料，请参见本说明的第x-65页。

当废碳粉盒已满时，会出现下列信息（如果由用户更换）。



细节

有关更换步骤的详细资料，请参见本说明的第 x-66 页。

需要更换成像组件时，会出现下列信息（如果由用户更换）。



细节

有关更换步骤的详细资料，请参见本说明的第 x-68 页。

## 更换碳粉盒

下列步骤说明如何更换碳粉盒。

对于所有颜色的碳粉，更换碳粉盒的步骤是相同的。作为示例，下面介绍了更换黑色碳粉盒的步骤。

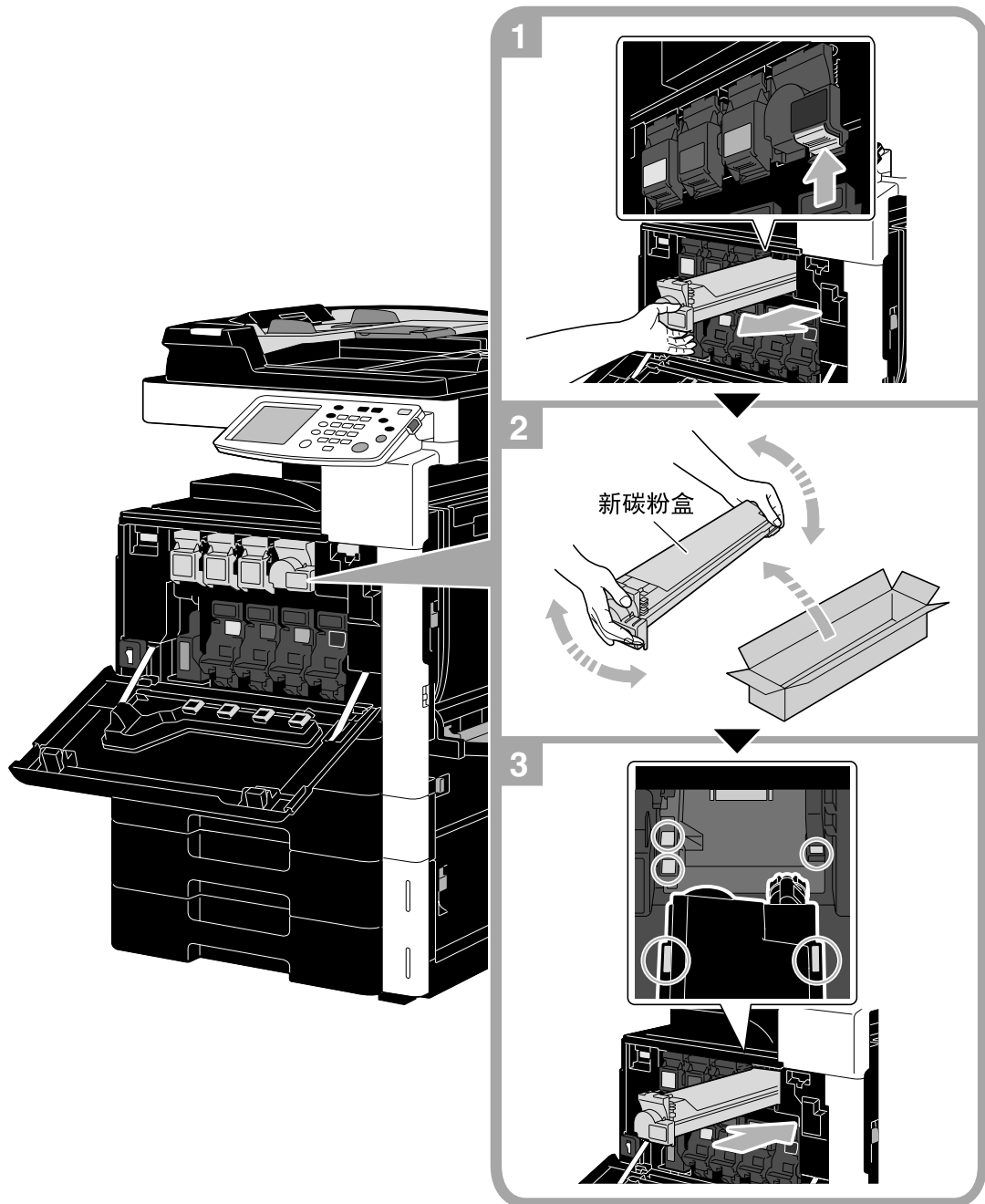

### 备注

安装新的碳粉盒之前，请上下摇晃五到十分钟。

将用过的碳粉盒放在盒子中的塑料袋里，由维修人员回收。

## ⚠ 注意

### 处理碳粉和碳粉盒

- 切勿点燃碳粉或碳粉盒。
- 从火中飞出的碳粉可能会引起烧伤。

## ⚠ 注意

### 碳粉飞溅注意事项

- 注意不要让碳粉撒落到机器内或沾染到衣服或手上。
- 如果手上沾染了碳粉，请立即用肥皂和水清洗。
- 如果碳粉进入眼睛，请立即用水冲洗，然后到专业医师处就诊。

### 更换废碳粉盒

下列步骤说明如何更换废碳粉盒。

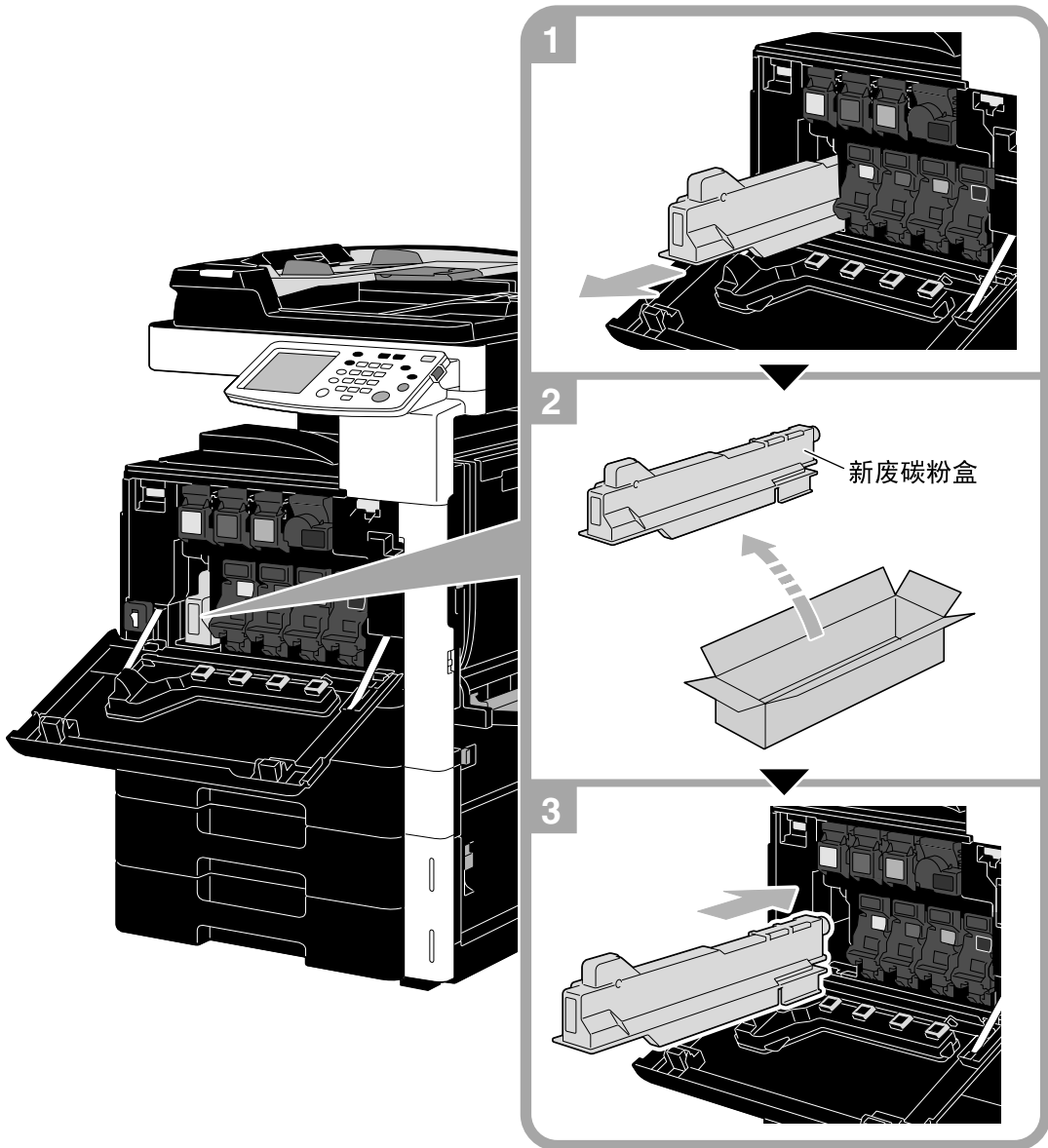

### 备注

将用过的废碳粉盒放在盒子中的塑料袋，由维修人员回收。

---

 **注意****处理碳粉和废碳粉盒**

- 切勿点燃碳粉或废碳粉盒。
  - 从火中飞出的碳粉可能会引起烧伤。
- 

 **注意****碳粉飞溅注意事项**

- 注意不要让碳粉撒落到机器内或沾染到衣服或手上。
  - 如果手上沾染了碳粉，请立即用肥皂和水清洗。
  - 如果碳粉进入眼睛，请立即用水冲洗，然后到专业医师处就诊。
-

## 更换成像组件

下列步骤说明如何更换成像组件。

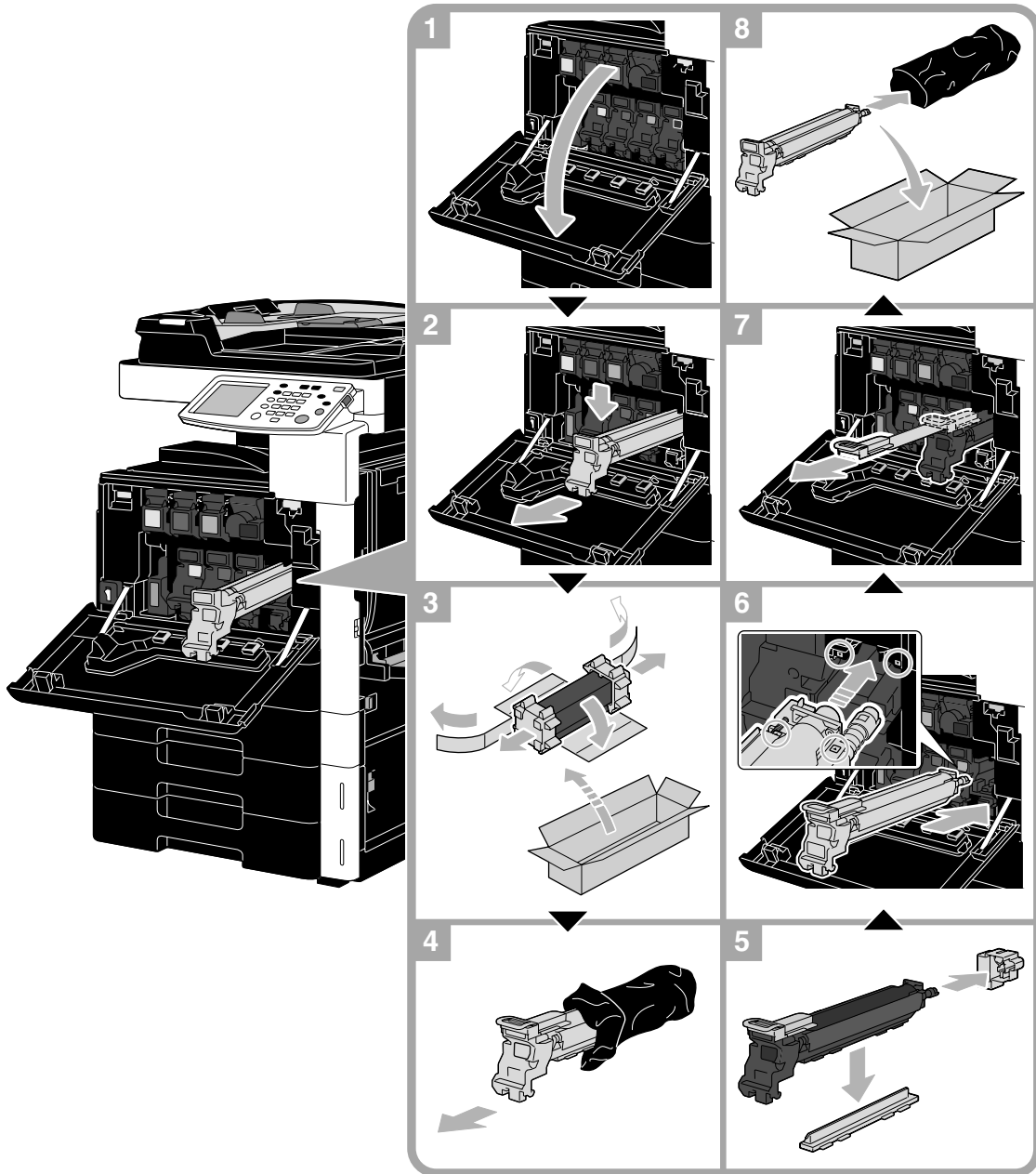

✎ ....

### 备注

更换成像组件时，将新的成像组件倾斜到左侧并按照倾斜方向轻轻摇动两次，然后将成像组件倾斜到右侧并按照倾斜方向轻轻摇动两次。

将用过的成像组件放在盒子中的黑色塑料袋，由维修人员回收。

## ⚠ 注意

### 碳粉飞溅注意事项

- ➔ 注意不要让碳粉撒落到机器内或沾染到衣服或手上。
- ➔ 如果手上沾染了碳粉，请立即用肥皂和水清洗。
- ➔ 如果碳粉进入眼睛，请立即用水冲洗，然后到专业医师处就诊。

## 选购件

本部分介绍了本机上所安装选购件的配置。

添加选购件后，可以满足各种办公需求。

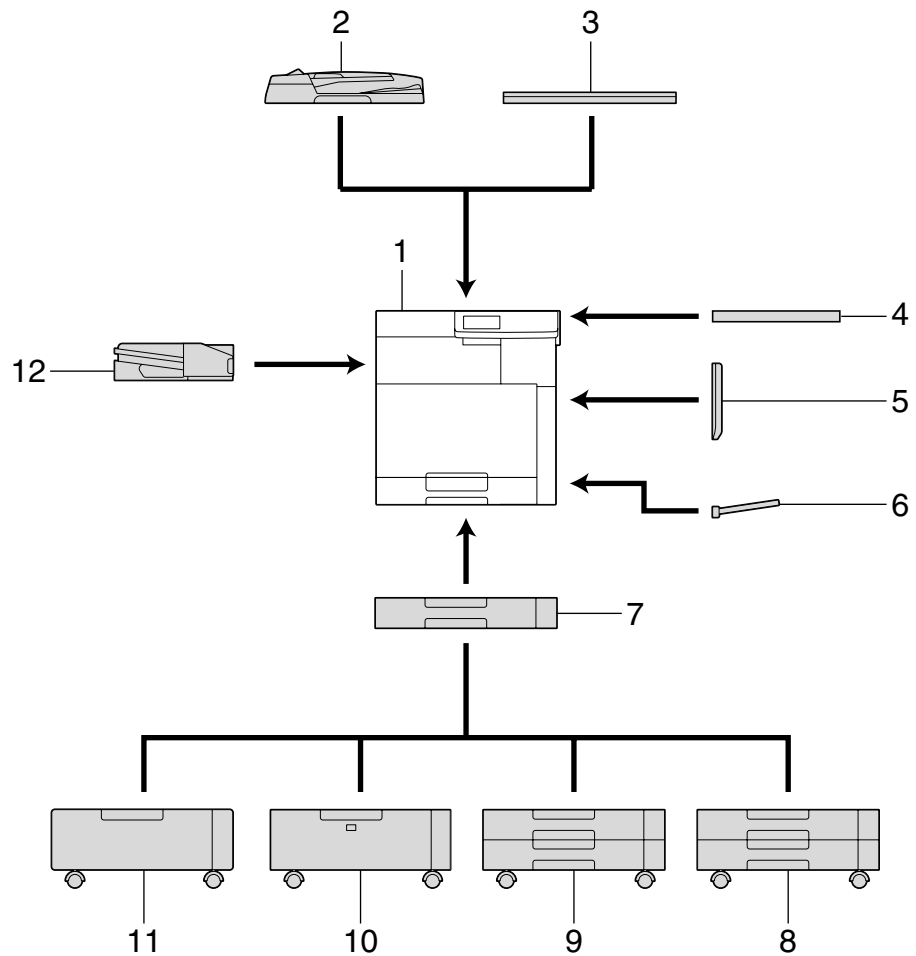

号码	零件名称	说明
1	主机	用扫描仪部分扫描文件，而通过打印机部分来打印所扫描的图像。 在本使用说明书中通篇称为“机器”、“主机”或“C210”。
2	自动双面输稿器 DF-612	一次自动送入一张文件进行扫描，然后自动翻转双面文件进行扫描。 在本使用说明书中通篇称为“ADF”。
3	原稿盖板 OC-508	按下装入的文件，将其保持在位置。 在本使用说明书中通篇称为“原稿盖板”。
4	物品托盘 WT-503	提供一个临时放置文件或其它材料的地方。
5	双面器 AD-505	翻转打印页，将双面页自动打印。 在本使用说明书中通篇称为“双面器组件”。
6	旁路送纸器 MB-502	最多可装入 100 张纸。 在本使用说明书中通篇称为“手送进纸盘”。
7	单纸盒纸柜 PC-105	最多可装入 500 张纸。 在本使用说明书中通篇称为“附加纸盒纸柜”。
8	单纸盒纸柜 PC-104	顶部纸盒最多可装入 500 张纸，底部纸盒可用作存放。 在本使用说明书中通篇称为“单纸盒纸柜”。
9	双纸盒纸柜 PC-204	顶部和底部纸盒最多可分别装入 500 张纸。 在本使用说明书中通篇称为“双纸盒纸柜”。
10	大容量纸盒 PC-405	最多可装入 2,500 张纸。 在本使用说明书中通篇称为“LCT”。
11	工作台 DK-504	允许本机在地面上安装。 在本使用说明书中通篇称为“工作台”。

号码	零件名称	说明
12	作业分离托盘 JS-505	安装在出纸盘上时，可以用来分离打印页。 在本使用说明书中通篇称为“分离托盘”。
13	Assist handle AH-101 <sup>*1</sup>	用于关闭原稿盖板或 ADF。
14	传真组件 FK-507 <sup>*2</sup>	允许本机用于传真。
15	多线传真安装组件 ML-504 <sup>*2</sup>	允许增加可进行传真的电话线路。
16	印记组件 SP-503 <sup>*2</sup>	为已被扫描的文件加盖印记。
17	备用发送印记 MS-501 <sup>*2</sup>	用来更换印记组件中的印记。
18	扩展内存 EM-310 <sup>*2</sup>	允许内存扩展 512 MB。 它便于通过使用打印机的各功能进行双面打印、安全打印、分页打印和直接打印 PDF 文件。此外，它还便于通过 TWAIN 驱动器扫描文件而无需压缩数据，并可以在安装了分离托盘后输出打印纸张。

<sup>\*1</sup> 以这种方式标记的部分未在图中显示。

<sup>\*2</sup> 以这种方式标记的部分为内部选购件，因此未在图中显示。



...

备注

有关详细资料，请参见使用说明书 [复印操作] 的第 1 章“开始复印之前”。



---



基本操作

## 1 基本操作

### 1.1 基本复印操作

本节包含有关复印操作的信息。

#### 1 放置要复印的原稿。

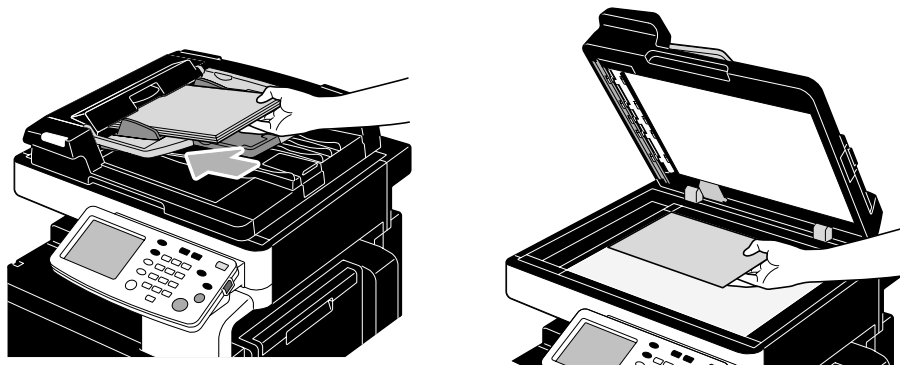

- 如果出现输入账户名和密码的屏幕，请输入必要的信息，然后触摸 [登录] 或按 [访问] 键。有关详细资料，请参见使用说明书 [复印操作] 的第 1 章“开始复印之前”。

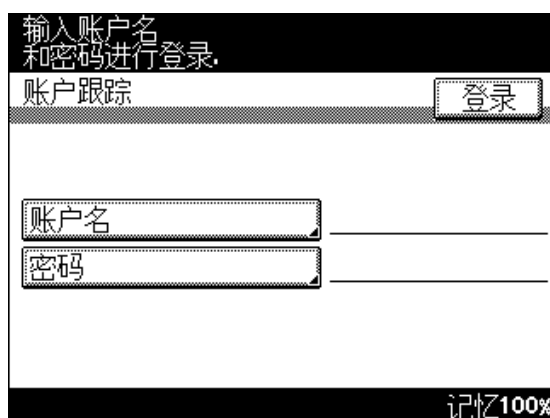

#### 2 选择基本屏幕设置。



- 彩色：选择原稿将以彩色还是以黑白复印。出厂默认情况下选择“自动彩色”。
- 纸张：选择要使用的纸盘。出厂默认情况下选择“自动纸张”。
- 缩放：进行放大/缩小复印时，更改缩放比率。出厂默认情况下选择“× 1.000”（满幅）。
- 单面/双面：复印双面原稿时或者对单面原稿进行双面复印时更改设置。出厂默认情况下选择“1>1”。
- 调用程序：可以调用编程的复印设置再次用来复印。

- 排纸处理：打印页可以按页或按份分类。
- 混合原稿：不同尺寸的原稿可以一起装入要进纸的 ADF 中并自动逐张扫描。另外，如果折叠原稿已装入 ADF 中进行复印，可以正确检测到原稿尺寸。
- 有关详细资料，请参见使用说明书 [复印操作] 的第 2 章“基本复印操作”和第 3 章“附加的复印操作”。

### 3 输入所需的份数。

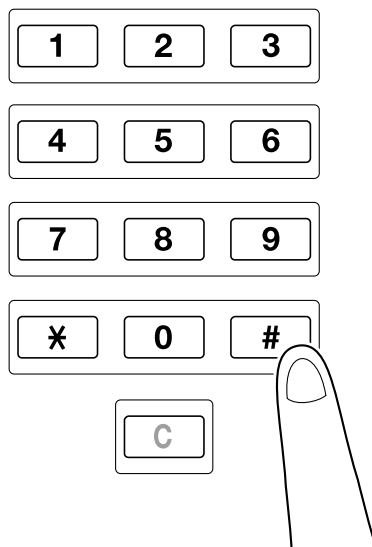

- 若要更改份数，按 [C]（清除）键，然后输入所需份数。
- 若要使用各种复印功能，触摸 [应用]，然后指定所需设置。有关详细资料，请参见使用说明书 [复印操作] 的第 7 章“应用功能”。



## 4 按 [开始] 键。

## 开始

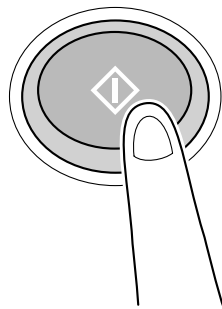

- 使用原稿台玻璃扫描多张文件页时（例如，打印组合复印件时），放置要扫描的第二张文件页，然后按 [开始] 键。重复该步骤直到扫描完所有页。扫描最后一页后，触摸 [结束]，然后按 [开始] 键。



- 若要停止扫描或复印，按 [停止] 键。
- 若要中断复印作业，按 [中断] 键。
- 有关停止复印的详细资料，请参见使用说明书 [复印操作] 的第2章“基本复印操作”。
- 有关中断复印的详细资料，请参见使用说明书 [复印操作] 的第3章“附加的复印操作”。

## 1.2 基本打印操作

本节包含有关打印操作的信息。

### 发送打印数据

在计算机上从应用程序通过打印机驱动程序将打印数据发送到本机。

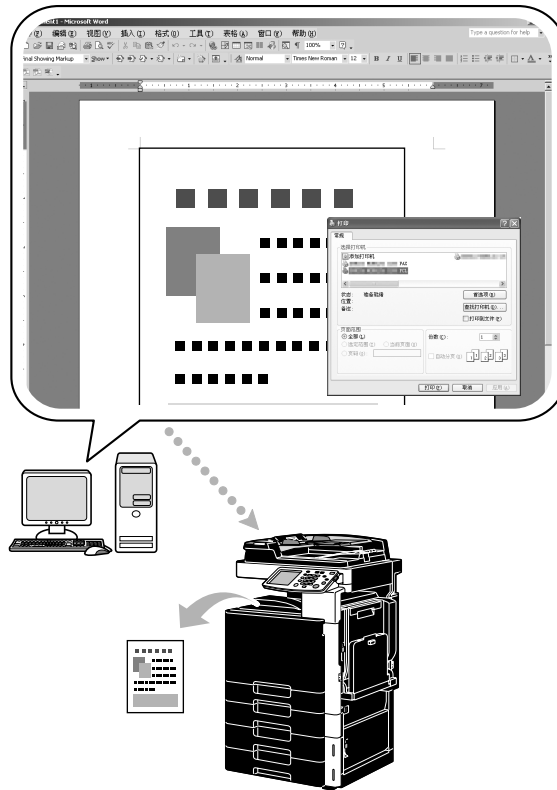

本机可以使用下列打印机驱动程序。

#### *Windows:*

柯尼卡美能达 PCL 驱动程序

柯尼卡美能达 PostScript 驱动程序

#### *Macintosh:*

OS X PostScript PPD 驱动程序

OS 9 PostScript PPD 驱动程序

## 打印之前

若要打印，必须首先在计算机上安装打印机驱动程序进行使用。

打印机驱动程序可以使用附带光盘上的安装程序轻松安装。（适用于 Windows）

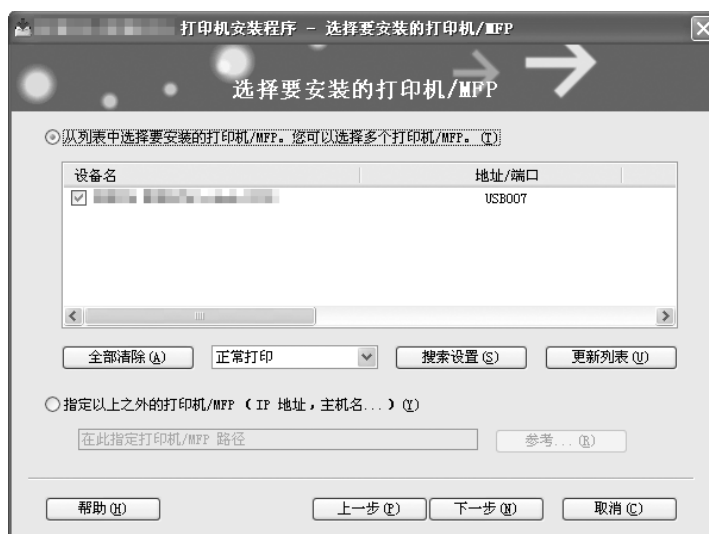

### 细节

若要打印，必须首先指定网络设置。

应由管理员来指定网络设置。

有关详细资料，请参见使用说明书 [网络管理员] 的第 1 章“指定网络设置”。

## 打印

- 1 在应用程序中创建文件，然后选择打印命令。

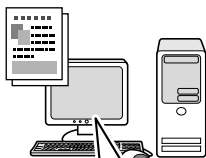

在打印对话框中，选择打印机。



- 如有必要，显示打印机驱动程序设置对话框，然后指定打印设置。



- 2 将打印指定页和份数。

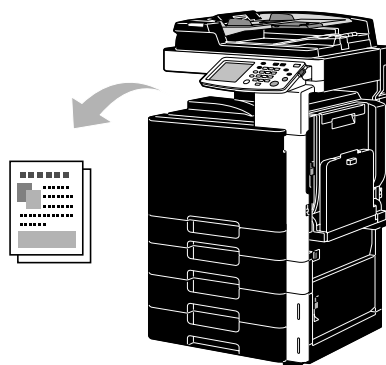

- 如果从打印机驱动程序中的“输出方式”下拉列表中选择“机密打印”，打印作业会作为机密文件打印作业保存在本机上。使用机器控制面板打印文件。





### 1.3 基本传真操作

本节包含有关传真操作的信息。

#### 1 更改模式。

#### 传真/扫描

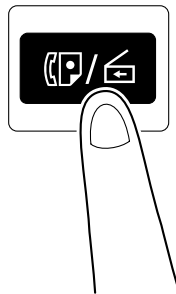

- 如果出现输入账户名和密码的屏幕，请输入必要的信息，然后触摸 [登录] 或按 [访问] 键。有关详细资料，请参见使用说明书 [复印操作] 的第 1 章“开始复印之前”。

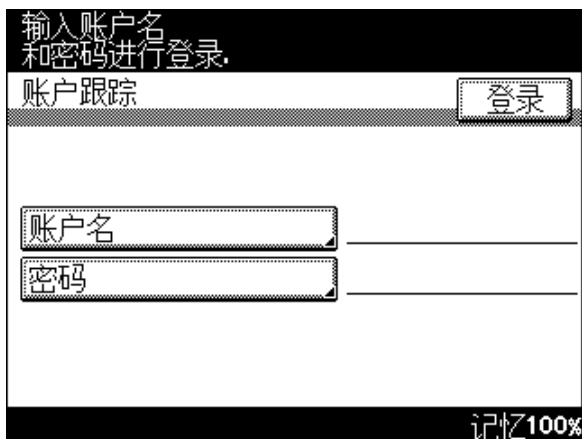

#### 2 选择目的地。



- 如果已经登录了传真号码，则可以选择注册目的地。有关注册目的地的详细资料，请参见本说明书的第 4-2 页。

- 直接输入传真号码时，触摸 [拨号]，然后使用数字键盘输入号码。



- 一份原稿可同时被发送到多个目的地（广播传送）。有关将原稿发送到多个目的地的详细资料，请参见本说明书的第 4-9 页。
- 如有必要，触摸 [质量] 或 [FAX 菜单]，然后指定所需设置。有关详细资料，请参见使用说明书 [网络扫描 / 传真 / 网络传真操作] 的第 4 章“传送数据”。

### 3 放置要传真的原稿。

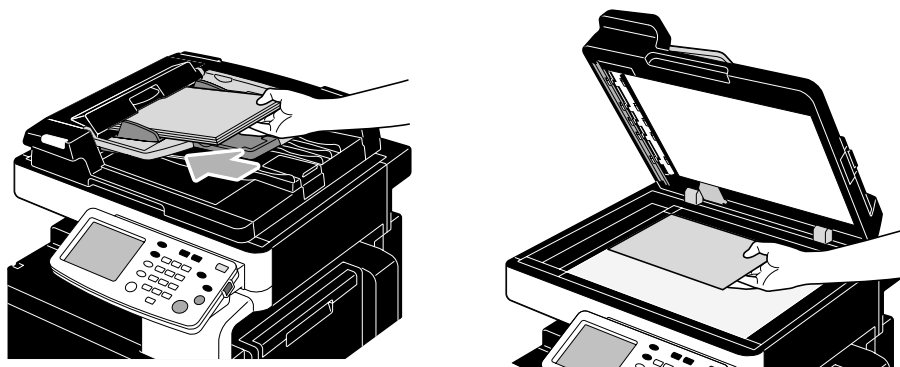

- 若要发送无法装入 ADF 的原稿（厚原稿或者在薄纸上原稿），请将其放在原稿玻璃上。
- 将原稿正面朝上放在 ADF 中，同时将原稿上边插入进纸槽。
- 若要检查为功能指定的目的地和设置，请按 [模式检查] 键。有关详细资料，请参见使用说明书 [网络扫描 / 传真 / 网络传真操作] 的第 2 章“控制面板 / 触摸面板”。



## 4 按 [开始] 键。

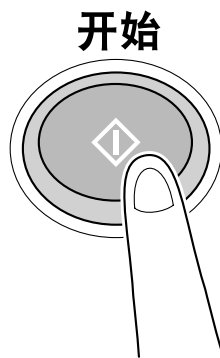

- 使用原稿台玻璃扫描多页原稿时，请放置第二页然后按 [开始] 键。重复该步骤直到扫描完所有页。扫描最后一页后，触摸 [结束]，然后按 [开始] 键。

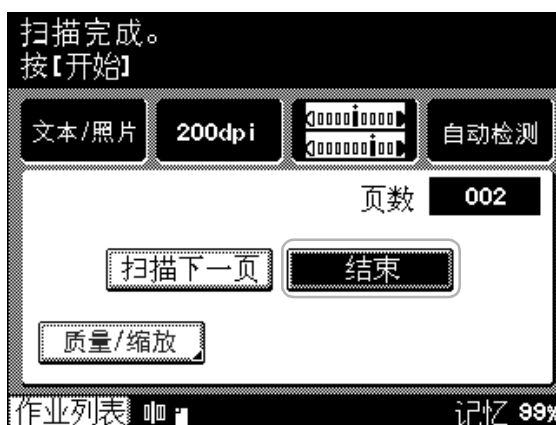

## 细节

若要在按 [开始] 键后停止传送，触摸 [作业列表]，再触摸 [类型]，然后删除要停止的作业。有关详细资料，请参见使用说明书 [网络扫描/传真/网络传真操作] 的第 2 章“控制面板/触摸面板”。



## 1.4 基本扫描操作

本节包含有关发送扫描数据的信息。

### 扫描数据传送

可以将本机扫描的原稿作为数据文件发送。有下列传送方式。

- 扫描到电子邮件：将扫描数据作为附件发送至电子邮件信息。
- 扫描到 FTP：将扫描数据发送到 FTP 服务器。
- 扫描到 SMB：将扫描数据发送到网络的计算机中的共享文件夹。

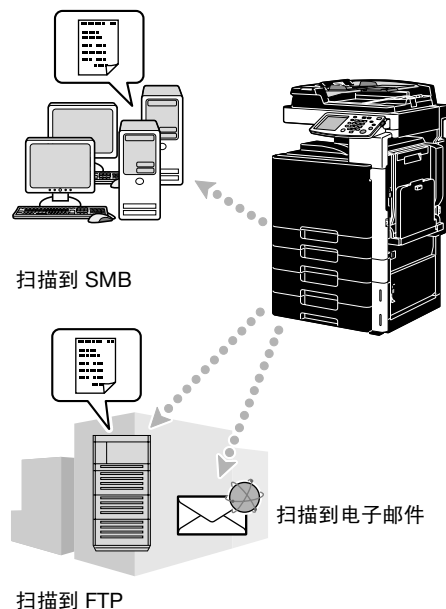

- 1 更改模式。

### 传真/扫描

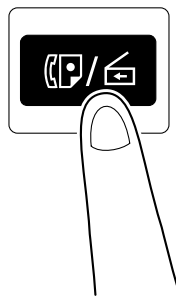

- 如果出现输入账户名和密码的屏幕，请输入必要的信息，然后触摸 [登录] 或按 [访问] 键。有关详细资料，请参见使用说明书 [复印操作] 的第 1 章“开始复印之前”。

输入账户名  
和密码进行登录。

账户跟踪 登录

---

账户名

密码

记忆100%

## 2 选择目的地。



- 如果已经登录了目的地，则可以选择注册目的地。有关注册目的地的详细资料，请参见本说明书的第 5-2 页。
- 若要直接输入电子邮件传送的目的地地址，触摸拨号选项中的 [更改模式]，选择传送方式，然后输入目的地地址。
- 如果未安装选购的传真组件，则会出现 [地址] 而不是 [拨号]。

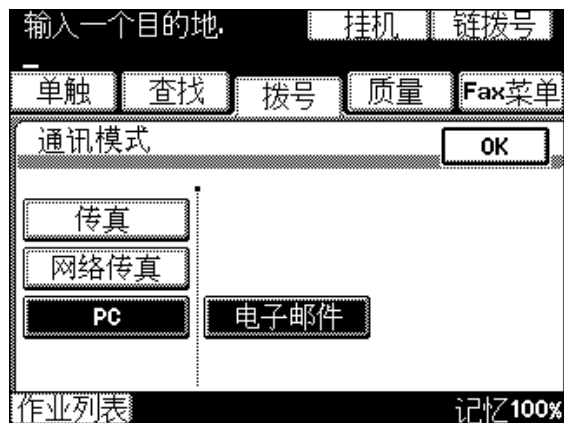

- 一份原稿可同时被发送到多个目的地（广播传送）。有关将原稿发送到多个目的地的详细资料，请参见本说明书的第 5-15 页。
- 如有必要，触摸 [质量] 或 [FAX 菜单]，然后指定所需设置。有关详细资料，请参见使用说明书 [网络扫描 / 传真 / 网络传真操作] 的第 4 章“传送数据”。

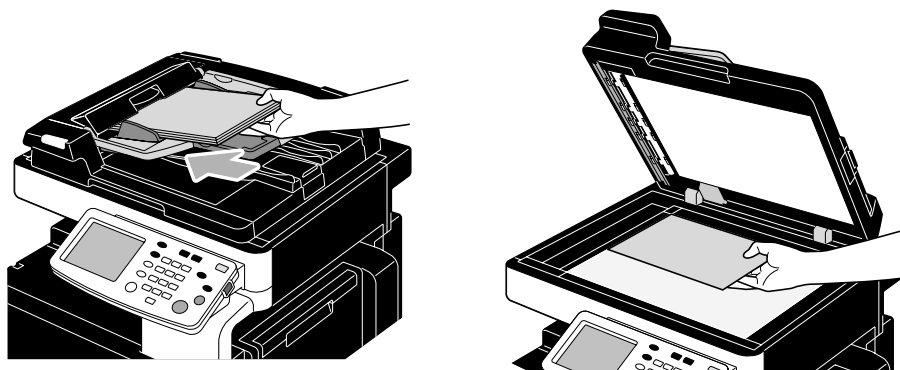
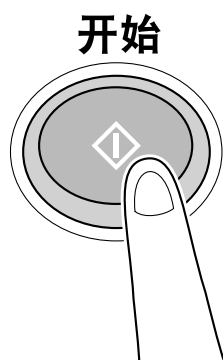
**3** 放置要扫描的原稿。**4** 按 [开始] 键。

- 使用原稿台玻璃扫描多页原稿时，请放置第二页然后按 [开始] 键。重复该步骤直到扫描完所有页。扫描最后一页后，触摸 [结束]，然后按 [开始] 键。

**细节**

在可以发送扫描数据之前，必须指定网络设置。

应由管理员来指定网络设置。

为了轻松操作，请事先根据所需应用指定除了网络设置之外的设置。

有关详细资料，请参见使用说明书 [网络管理员] 的第2章“指定机器功能（软件转换设置）”。

---



## 有用的复印操作

## 2 有用的复印操作

### 2.1 复印时减少纸张使用

双面复印（在纸张两面上打印）和组合复印（减少多页并将其一起打印在一张纸上）可方便地减少纸张使用并降低用来存放的办公室空间。

#### 双面复印

打印很多张单面原稿时，双面打印可降低纸张使用的一半。

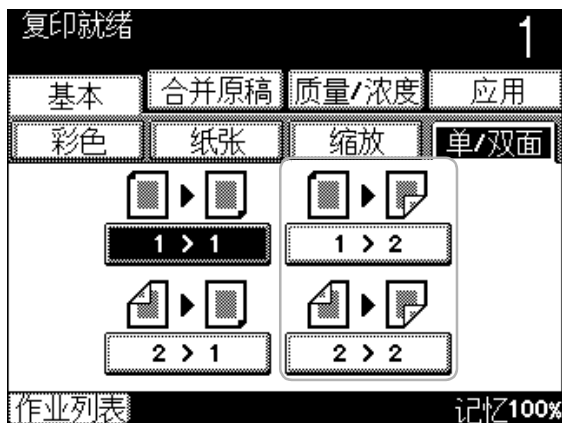
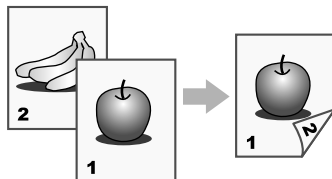





**细节**

只有安装选购的双面器组件时才可以**使用双面复印**。

只有在安装选购的ADF时才可以**使用“2>1”和“2>2”**。



**备注**

有关详细资料，请参见使用说明书 [复印操作] 的第2章“基本复印操作”。

**组合复印**

根据可在一张纸上打印的页数，选择“2合1”或“4合1”。将这些设置结合双面复印一起使用可进一步降低纸张使用。

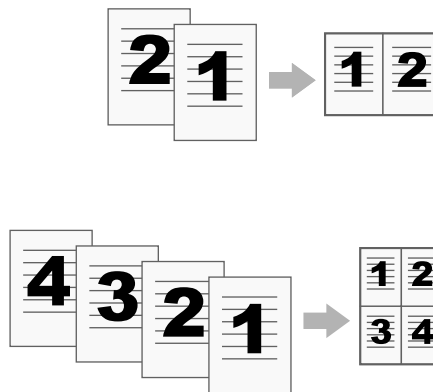

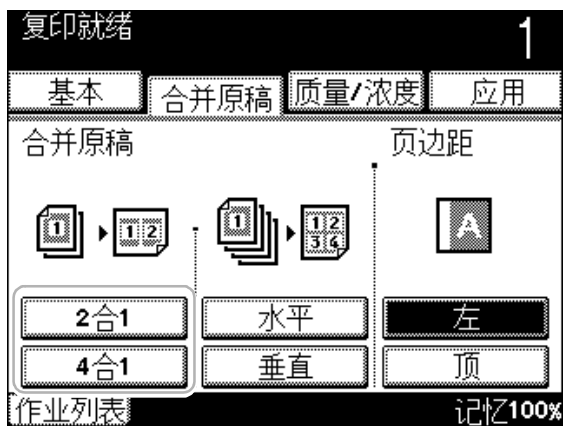

如果选择了“4合1”，则可以选择纸张排列。

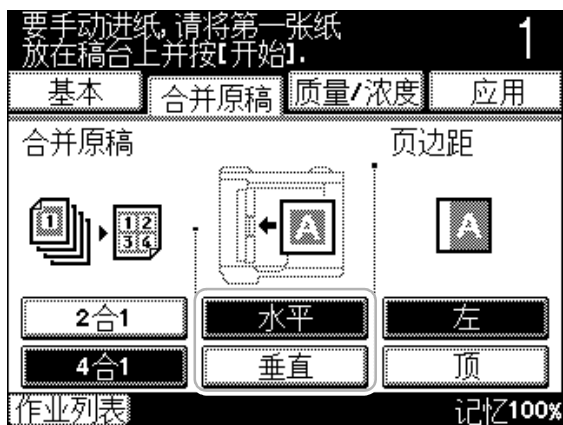

备注

有关详细资料, 请参见使用说明书 [复印操作] 的第2章“基本复印操作”。

## 2.2 在不同尺寸的纸张放大 / 缩小打印

### 自动缩放

可根据装入原稿的尺寸以及所指定的纸张尺寸自动选择缩放比率进行复印。

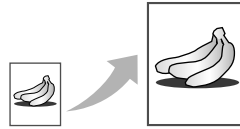

### 提醒

在比原稿大的纸张上复印时，请装入与纸张相同方向的原稿。

如果选择了“自动”缩放设置，则无法选择“自动纸张”设置。选择装入所需纸张尺寸的纸盒。

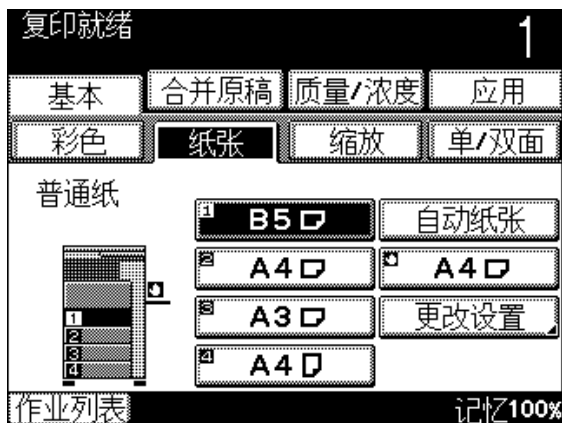

...  
备注

有关详细资料，请参见使用说明书 [复印操作] 的第2章“基本复印操作”。

## 2.3 在信封上复印

### 纸盒 1 / 手送进纸盒

在信封上复印时选择纸盒 1 或手送进纸盒。

在信封上复印时，原稿和纸张的方向特别重要。

#### 1 放置原稿。

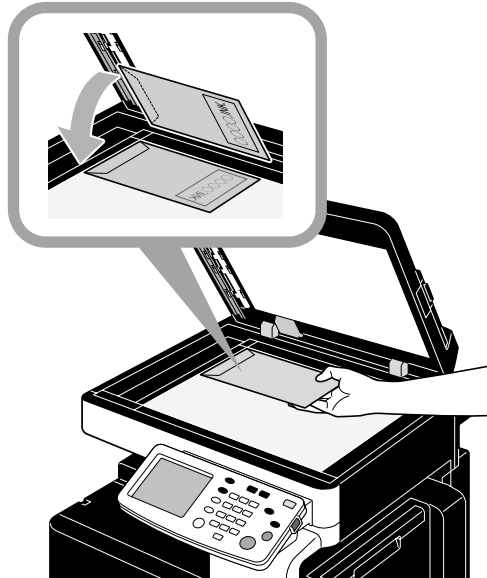

2 在纸盒中装入纸张。

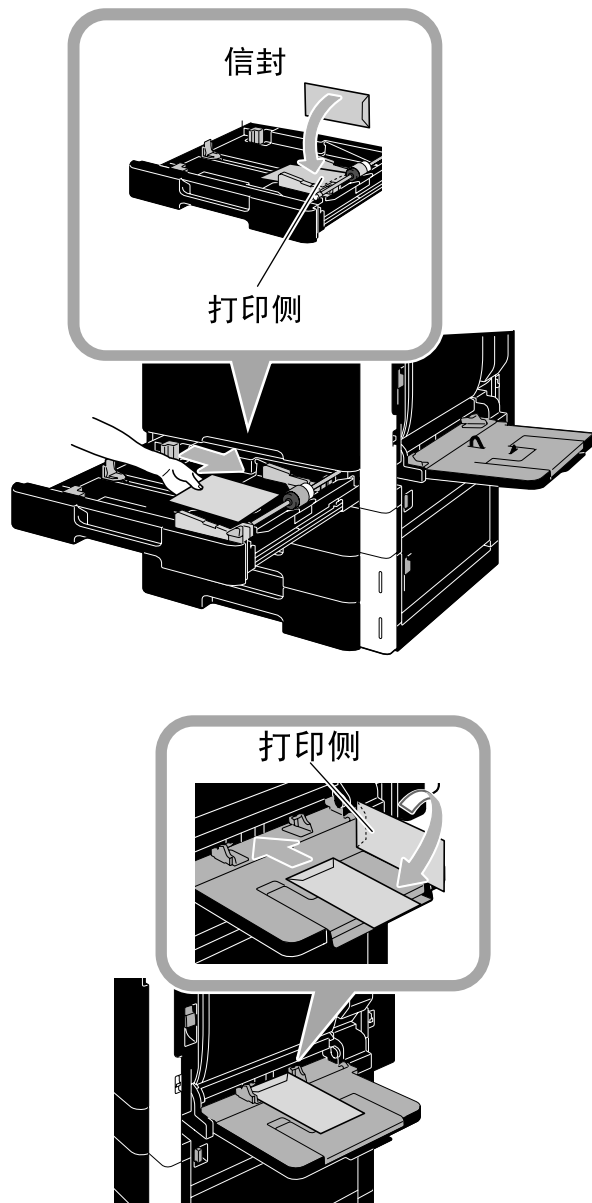

- 将介质装入纸盒 1，使要打印的一侧朝上。将介质装入手送进纸盒，使要打印的一侧朝下。

## 3 指定纸张类型和尺寸。

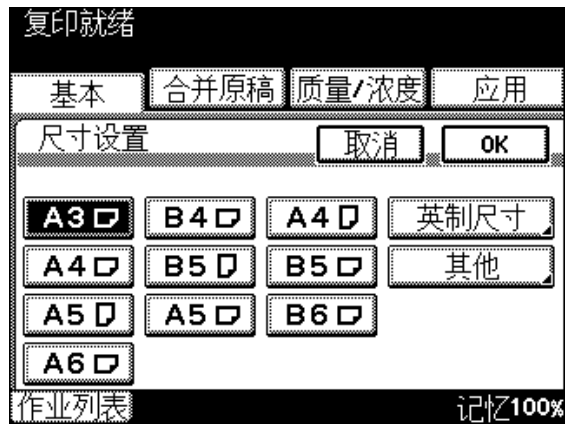

- 如果装入了信封，请选择“信封”纸张类型设置。选择符合所装入信封尺寸的尺寸。



备注

有关详细资料，请参见使用说明书 [复印操作] 的第1章“开始复印之前”。

## 2.4 轻松调出经常使用的功能

注册 / 调出程序

经常使用的功能可作为复印程序注册。注册的复印程序可被轻松调出和使用。

注册程序

首先，指定要注册的功能。



模式检查

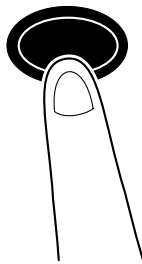



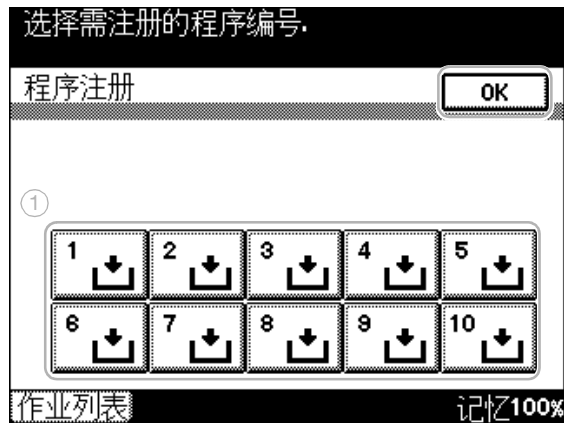

细节

最多可以注册 10 个复印程序。

调出程序





...

备注

有关详细资料，请参见使用说明书 [复印操作] 的第3章“附加的复印操作”。

## 2.5 检查打印数

### 用量计数器

可以检查各种功能的打印总页数和详细打印计数，例如黑白打印的数量。

### 效用/计数器

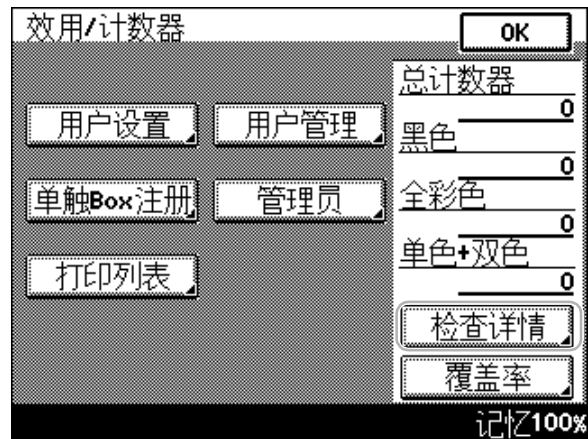
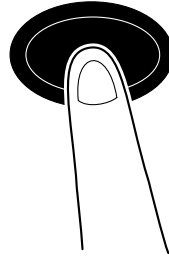

下列信息可以在复印选项中查看。



总计：显示使用“黑色”设置、“全彩色”设置、“单色”设置、“双色”设置进行复印的总数，以及所有彩色设置的总数。

大尺寸：显示使用“黑色”设置、“全彩色”设置、“单色”设置、“双色”设置在大尺寸纸张上进行复印的总数，以及所有彩色设置的总数。

+ 打印：显示使用“黑色”设置、“全彩色”设置和“双色”设置进行复印和打印的总页数。



细节

如需打印列表，触摸 [打印表]。



备注

有关详细资料，请参见使用说明书 [复印操作] 的第9章“机器的维护”。

## 2.6 降低电量消耗

本机具有可节省能量的节能功能。

在管理员模式中指定这些功能的设置。

### LCD 背光关闭 / 低耗电模式 / 睡眠模式

如在指定时间内未在机器上进行任何操作，则机器自动进入节能模式。如果在 1 分钟内未在机器上进行任何操作，触摸面板和 LCD 背光熄灭。过 10 分钟后，机器进入低耗电模式。如果在 20 分钟内未进行任何操作，机器进入节能效果更大的睡眠模式（出厂默认设置）。



...

**备注**

有关详细资料，请参见使用说明书 [复印操作] 的第 1 章“开始复印之前”。



---



## 有用的打印操作

## 3 有用的打印操作

### 3.1 选择纸张

#### 原稿方向

选择“纵向”或“横向”作为在纸张上打印的方向。



纵向



横向

Windows PCL/PS 驱动程序：基本选项

Macintosh OS X 驱动程序：页面属性



#### 备注

有关详细资料，请参见使用说明书 [打印操作] 的第7章“适用于Windows的PCL/PS驱动程序的打印功能”和第8章“Mac OS X的打印功能”。

#### 原稿尺寸和纸张尺寸

选择原稿的纸张尺寸和要打印纸张的尺寸。

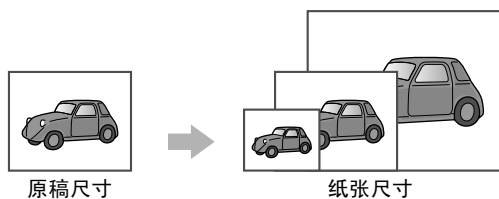

Windows PCL/PS 驱动程序：基本选项

Macintosh OS X 驱动程序：页面属性



#### 备注

有关详细资料，请参见使用说明书 [打印操作] 的第7章“适用于Windows的PCL/PS驱动程序的打印功能”和第8章“Mac OS X的打印功能”。



### 缩放

指定放大或缩小比率。

原稿与“原稿尺寸”设置中不同并且“缩放”设置为“自动”时，原稿被自动放大或缩小为此处指定的尺寸。

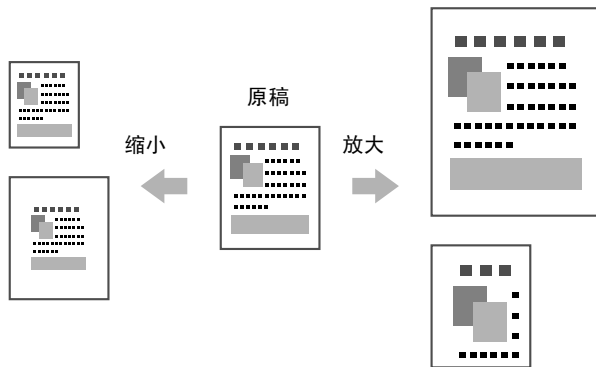

Windows PCL/PS 驱动程序：基本选项

Macintosh OS X 驱动程序：页面属性



#### 细节

Windows PCL/PS 驱动程序也具有“细线支持”功能，在以缩小尺寸打印时可防止细线变模糊。（其它选项）



#### 备注

有关详细资料，请参见使用说明书 [打印操作] 的第 7 章“适用于 Windows 的 PCL/PS 驱动程序的打印功能”和第 8 章“Mac OS X 的打印功能”。

### 纸盒（纸张类型）

选择要使用的纸盒。如果纸盒中装入了不同类型的纸张，可以通过选择不同的纸盒来选择所需纸张类型。

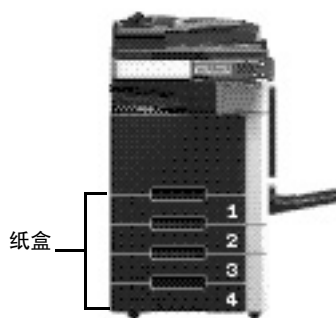

Windows PCL/PS 驱动程序：基本选项

Macintosh OS X 驱动程序：纸盒



#### 细节

可选项目因安装的选购件而异。



...

备注

有关详细资料，请参见使用说明书 [打印操作] 的第7章“适用于Windows的PCL/PS 驱动程序的打印功能”和第8章“Mac OS X 的打印功能”。

### 复印和分页 / 偏移

打印多份时，选择“分页”功能将每份作为一整套打印（1, 2, 3, ..., 1, 2, 3, ...）。

另外，如果选择了“偏移”功能，每套复印件输出时会向前或向后偏移。

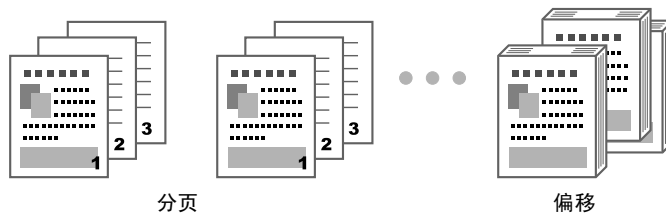

Windows PCL/PS 驱动程序：基本选项

Macintosh OS X 驱动程序：输出方式



细节

只有安装选购的扩展内存时才可以使用“分页”功能。

只有安装选购的分离托盘和扩展内存时才可以使用“偏移”功能。



...

备注

有关详细资料，请参见使用说明书 [打印操作] 的第7章“适用于Windows的PCL/PS 驱动程序的打印功能”和第8章“Mac OS X 的打印功能”。

### 3.2 管理和限制打印

#### 机密打印

可以为文件指定密码。

由于除非在机器控制面板中输入密码否则无法检索文件，该功能在打印机密文件时非常有用。

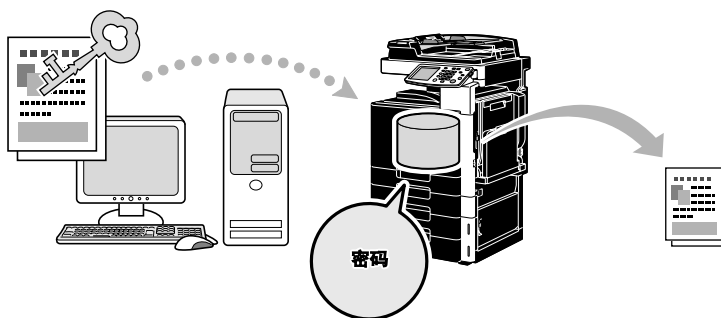

Windows PCL/PS 驱动程序：基本选项

Macintosh OS X 驱动程序：输出方式



#### 细节

只有安装选购的扩展内存时才可以使使用“机密打印”功能。



#### 备注

有关详细资料，请参见使用说明书 [打印操作] 的第 10 章“功能详细说明”。

#### 账户跟踪

如果在机器上指定了账户跟踪设置，在打印机驱动程序中注册账户信息可让机器检查已发送的打印作业是否从注册账户中发送的数据。

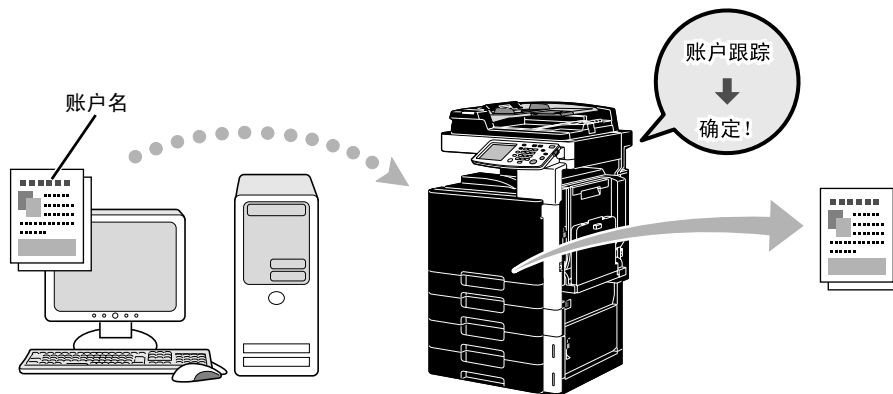

Windows PCL/PS 驱动程序：基本选项

Macintosh OS X 驱动程序：输出方式



#### 备注

有关详细资料，请参见使用说明书 [打印操作] 的第 10 章“功能详细说明”。

### 3.3 打印时减少纸张使用

#### 组合

N 分页打印，可减少多页文件页数并可将其一起打印在一张纸上，可有效节省打印页的数量。

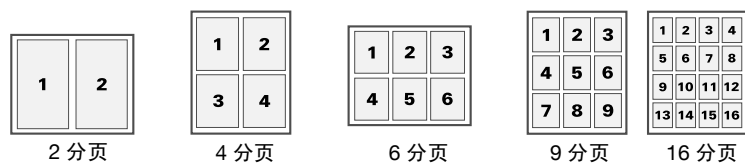

Windows PCL/PS 驱动程序：布局选项



...

#### 备注

有关详细资料，请参见使用说明书 [打印操作] 的第 7 章“适用于 Windows 的 PCL/PS 驱动程序的打印功能”。

#### 双面打印

文件页面可以在纸张的两面上打印。

该功能适用于装订多页文件。

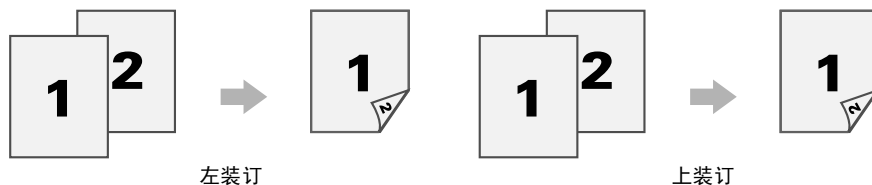

Windows PCL/PS 驱动程序：布局选项

Macintosh OS X 驱动程序：布局



#### 细节

只有安装选购的双面器组件和扩展内存时才可以使使用双面打印。

“抑制空白页”功能，在从 Windows PCL 驱动程序中打印时不会打印空白页，可有效减少纸张使用。



...

#### 备注

有关详细资料，请参见使用说明书 [打印操作] 的第 7 章“适用于 Windows 的 PCL/PS 驱动程序的打印功能”和第 8 章“Mac OS X 的打印功能”。

### 3.4 调整打印位置

#### 装订方向和装订边距

指定装订位置进行装订文件。使用 Windows PCL/PS 驱动程序时，也可以调整页边距量。

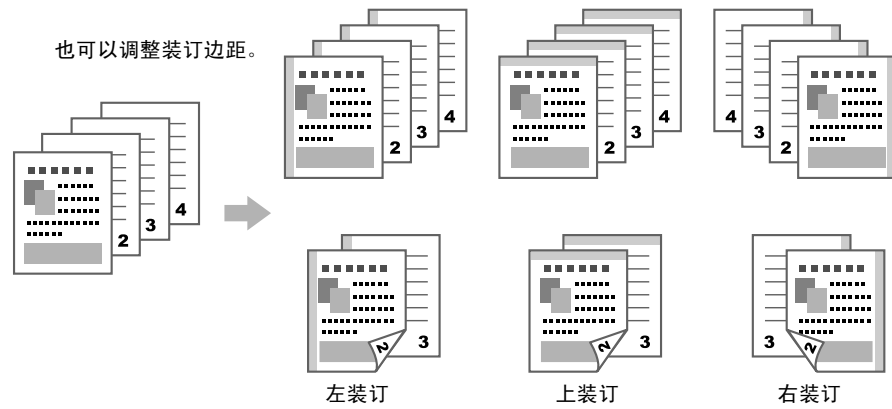

Windows PCL/PS 驱动程序：布局选项

Macintosh OS X 驱动程序：布局



#### 备注

有关详细资料，请参见使用说明书 [打印操作] 的第7章“适用于 Windows 的 PCL/PS 驱动程序的打印功能”和第8章“Mac OS X 的打印功能”。

### 3.5 打印时添加文字和图像

#### 水印

文件可以重叠水印（文字印记）来打印。

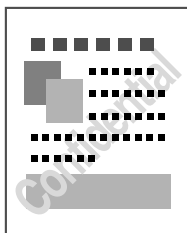

Windows PCL/PS 驱动程序：印记 / 排版选项



#### 备注

有关详细资料，请参见使用说明书 [打印操作] 的第7章“适用于Windows的PCL/PS驱动程序的打印功能”。

#### 叠图

文件可以重叠单独的叠图数据来打印。

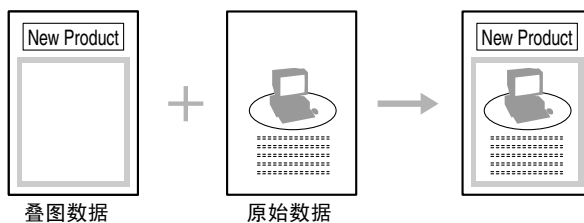

Windows PCL/PS 驱动程序：印记 / 排版选项



#### 备注

有关详细资料，请参见使用说明书 [打印操作] 的第7章“适用于Windows的PCL/PS驱动程序的打印功能”。

### 3.6 调整图像质量

#### 选择颜色和质量调整

文件可灰度级打印，或者可以调整图像质量，如色调。



Windows PCL/PS 驱动程序：图像品质选项

Macintosh OS X 驱动程序：图像品质

...  
备注

有关详细资料，请参见使用说明书 [打印操作] 的第 7 章“适用于 Windows 的 PCL/PS 驱动程序的打印功能”和第 8 章“Mac OS X 的打印功能”。

#### 颜色设置

文件可以使用适用于文件内容的图像质量打印。

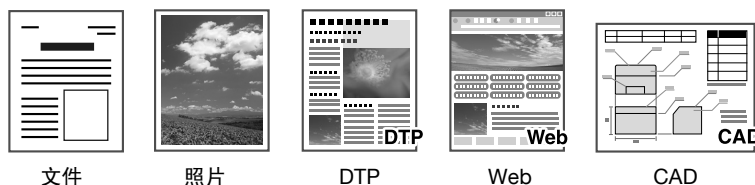

Windows PCL/PS 驱动程序：图像品质选项

Macintosh OS X 驱动程序：图像品质

...  
备注

有关详细资料，请参见使用说明书 [打印操作] 的第 7 章“适用于 Windows 的 PCL/PS 驱动程序的打印功能”和第 8 章“Mac OS X 的打印功能”。

#### 光泽模式

文件可以使用光泽外观来打印。

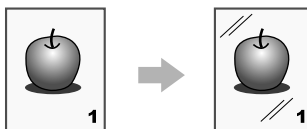

Windows PCL/PS 驱动程序：图像品质选项

Macintosh OS X 驱动程序：图像品质

...  
备注

有关详细资料，请参见使用说明书 [打印操作] 的第 7 章“适用于 Windows 的 PCL/PS 驱动程序的打印功能”和第 8 章“Mac OS X 的打印功能”。

## 3.7 使用打印机字体

### 字体设置

可以使用打印机字体替代 TrueType 字体来打印文件。

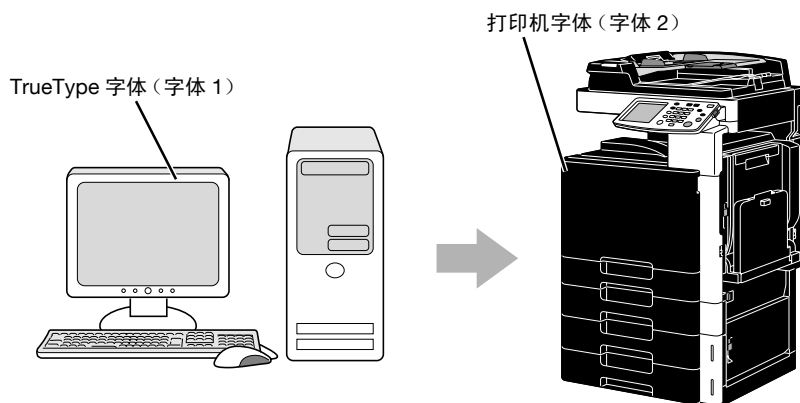

Windows PCL/PS 驱动程序：图像品质选项



#### 细节

使用打印机字体时，可减少打印时间，但在所显示文件和打印结果之间可能会有差别。



#### 备注

有关详细资料，请参见使用说明书 [打印操作] 的第 7 章“适用于 Windows 的 PCL/PS 驱动程序的打印功能”。



---



有用的传真操作

## 4 有用的传真操作

### 4.1 注册经常使用的传真号码

可以注册经常使用的目的地。

#### 单触键

在单触键中注册经常使用的目的地，只要触摸以下单触键便可调出目的地。

*选择要编程的按钮*

#### 效用/计数器

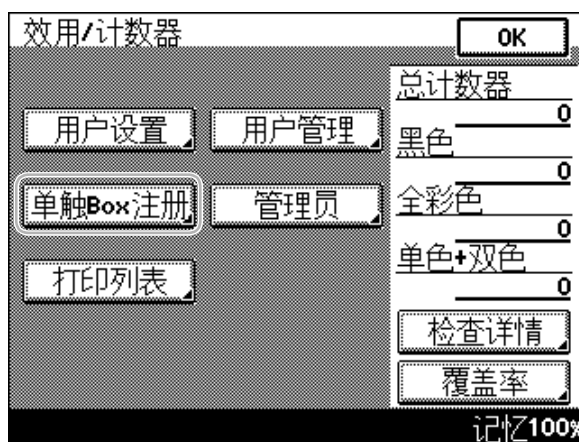
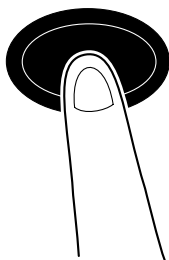

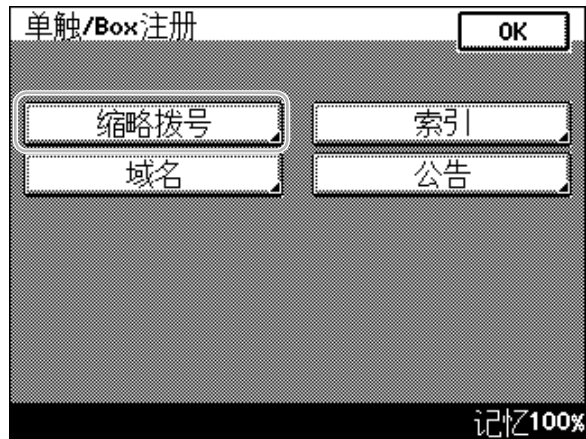

...  
备注

如果已注册了要搜索的 LDAP 服务器，可以将 LDAP 服务器上注册的地址注册为单触目的地。

注册传真号码



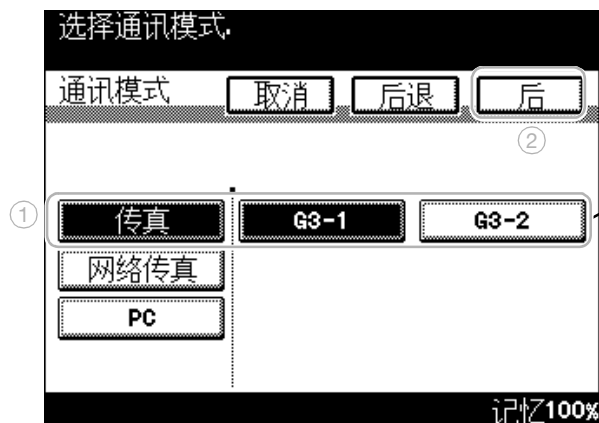

若要注册传真号码, 触摸 [传真]。

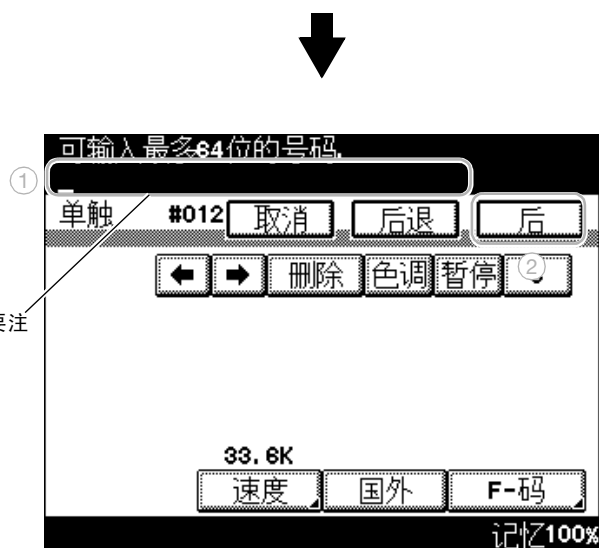

使用数字键盘, 输入要注册的传真号码。



备注

有关详细资料, 请参见使用说明书 [网络扫描 / 传真 / 网络传真操作] 的第2章 “控制面板 / 触摸面板” 和第8章 “用户设置 / 用户管理 / 单触 / Box 注册”。

### 注册程序

只需一个按钮便可注册扫描设置、传送设置和目的地。



#### 细节

触摸单触拨号按钮可以指定目的地。

指定质量、传真菜单和拨号选项上的设置。



### 模式检查

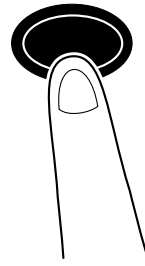

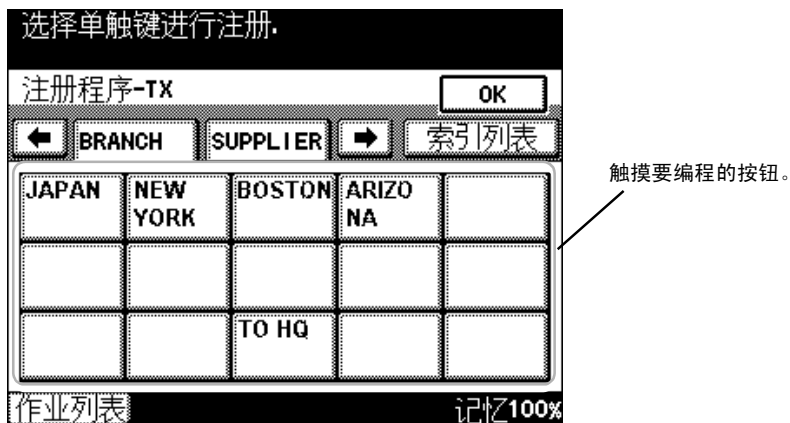
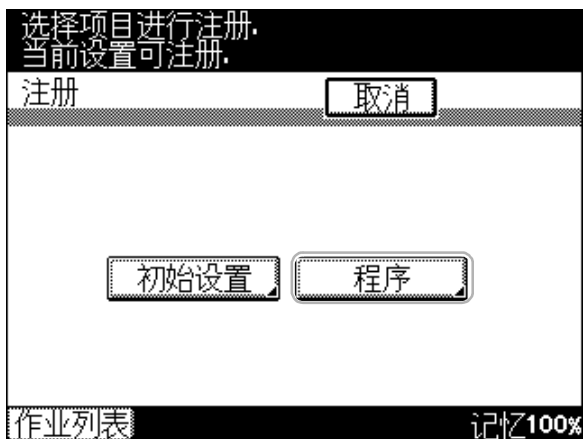

....  
备注

有关详细资料，请参见使用说明书 [网络扫描 / 传真 / 网络传真操作] 的第8章 “用户设置 / 用户管理 / 单触 / Box 注册”。

## 4.2 检查目前为止执行的传真操作

### 通信列表

可以在报告中查看传送和接收的日志并打印。

通信列表中有传送报告、接收报告以及综合了传送和接收报告的活动报告。可以手动打印传送报告和接收报告。

### 效用/计数器

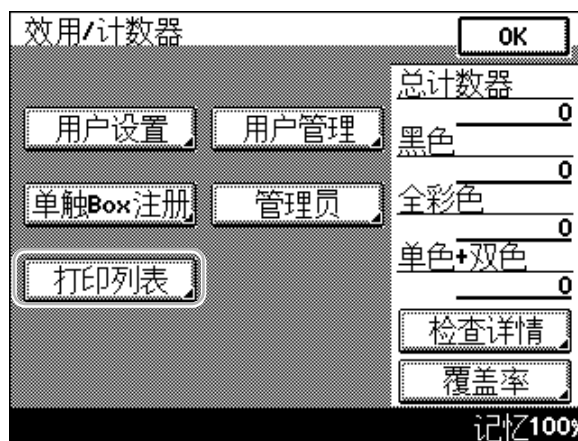
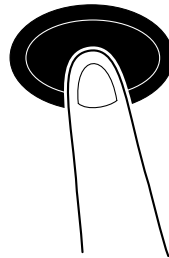

选择要打印的报告。

**细节**

每进行 50 次传送和接收作业后将打印活动报告。

可以定期打印传送报告和接收报告。

从管理员管理屏幕中指定打印报告的设置。

无法发送的文件可从作业列表中选择并手动发送。有关详细资料，请参见使用说明书 [网络扫描 / 传真 / 网络传真操作] 的第 4 章 “传送数据”。



...

**备注**

有关详细资料，请参见使用说明书 [网络扫描 / 传真 / 网络 / 网络传真操作] 的第 7 章 “报告 / 列表的说明”。



### 4.3 同时向多个收件人传送

只要一次操作便可将原稿发送到多个收件人。这叫做“广播传送”。

#### 广播传送

可以使用数字键盘输入目的地或者从单触键中选择来指定收件人。另外，可以组合这两种方法来指定收件人。

#### 从单触键中选择

选择要发送传送的多个目的地。

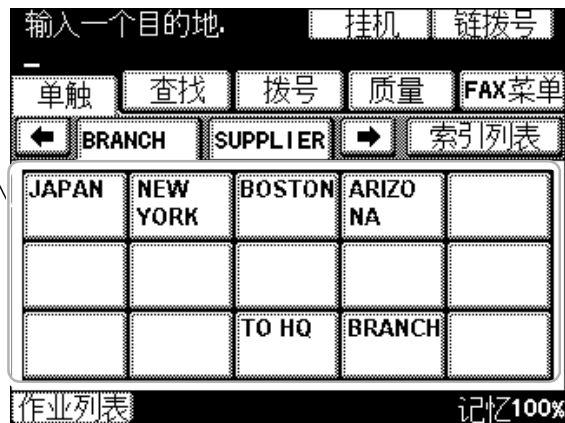

开始

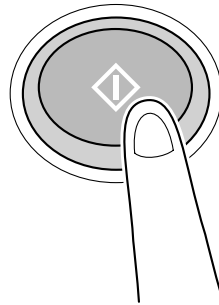



检查作业详细

注册

#000	JAPAN	123451234
#001	NEW YORK	123123123
#002	BOSTON	123456789

1/1 目的地: 3 下地址

质量 菜单

作业列表 记忆100%

使用数字键盘输入目的地

触摸 [增加] 显示输入备用目的地的屏幕。

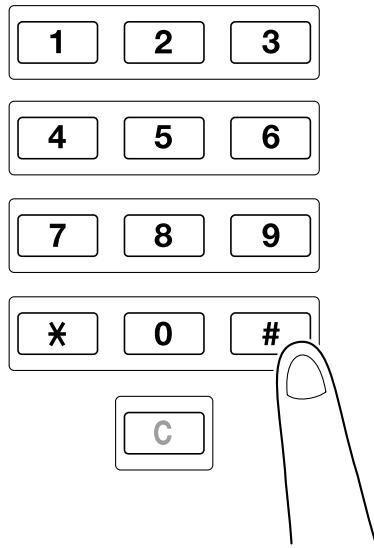
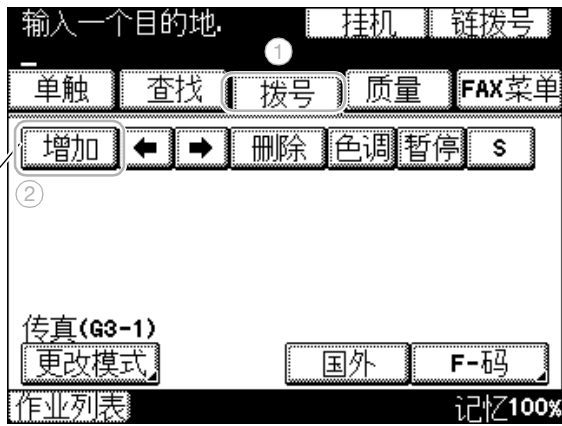

开始

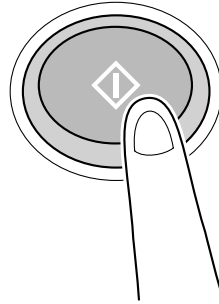



#### 细节

最多可以指定 210 个目的地。使用数字键盘时最多可以指定 12 个目的地。



#### 备注

有关详细资料，请参见使用说明书 [网络扫描 / 传真 / 网络传真操作] 的第 4 章 “传送数据”。

### 4.4 选择注册的传送源信息

#### 传真传送信息设置

可以选择并更改注册传送源信息（传送源名称和传真 ID）。

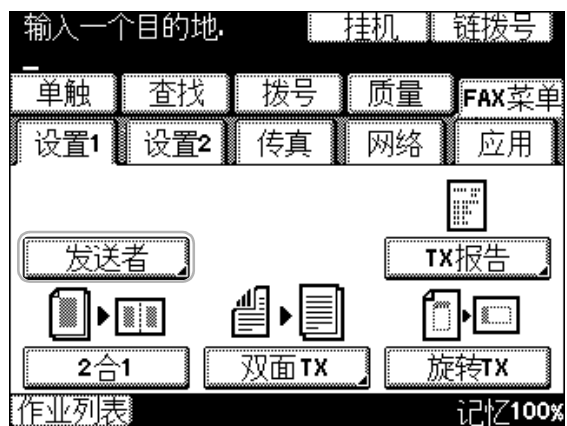
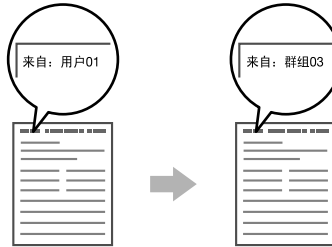



#### 细节

传送源信息在管理员管理屏幕中指定。与机器管理员确认管理员密码。  
 传送源信息是由管理员注册的。与机器管理员确认注册的信息。  
 管理员可在原稿外部或内部设置打印传送源信息的位置。



#### 备注

有关详细资料，请参见使用说明书 [网络扫描 / 传真 / 网络传真操作] 的第4章“传送数据”。

### 4.5 扫描要发送的原稿

#### 质量

在质量屏幕中，可以更改像图像质量、扫描原稿的分辨率和浓度的设置。

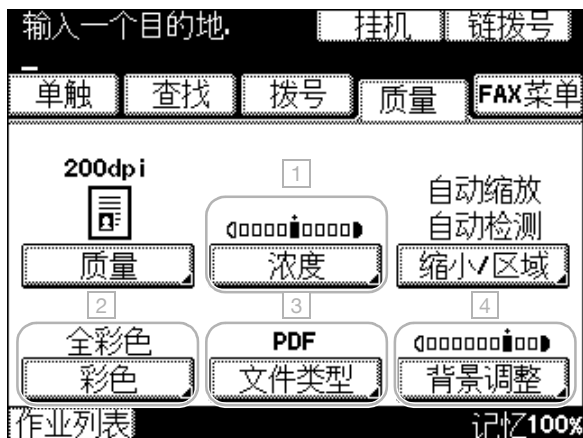

号码	参数	说明
1	浓度	选择让扫描数据的颜色变深还是变浅。
2	彩色	该参数在向传真号码发送时无法使用。
3	文件类型	该参数在向传真号码发送时无法使用。
4	背景调整	可以调节彩色原稿背景的浓度。

## 质量

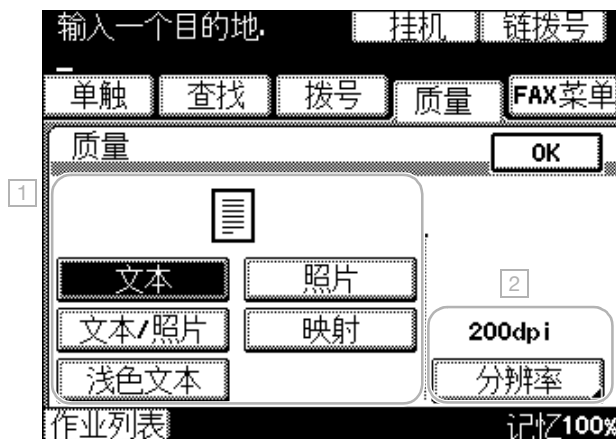

号码	参数	说明
1	质量	可以根据内容扫描原稿。
2	分辨率	数字越大，图像便越清晰。

## 缩小 / 区域



号码	参数	说明
1	缩放	缩放比率可根据装入收件人机器中的纸张尺寸自动选择，或者可以将文件切割为适合纸张尺寸（不缩小）。
2	扫描范围	指定要扫描文件的区域。



## 备注

有关详细资料，请参见使用说明书 [网络扫描 / 传真 / 网络传真操作] 的第4章“传送数据”。



### 4.6 使用从收件人发出的命令发送文件

#### 查询传送

将扫描原稿数据保存在发送者的机器上并使用收件人的请求发送叫做“查询传送”。

使用本机的“查询TX”功能发送的文件保存在本机内存中并且在从收件人接收到请求时发送。

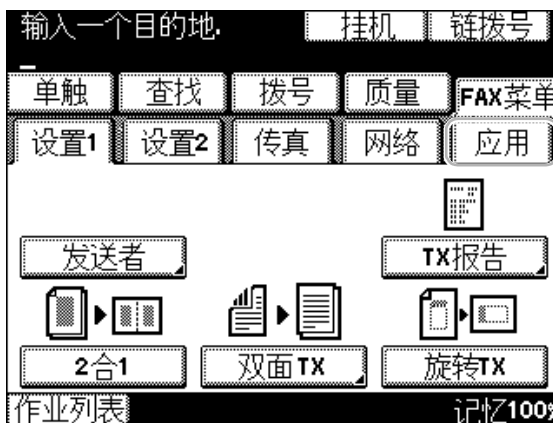
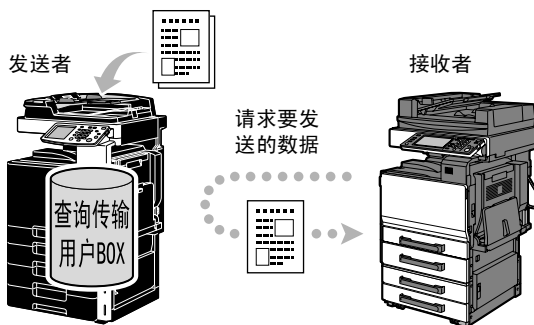

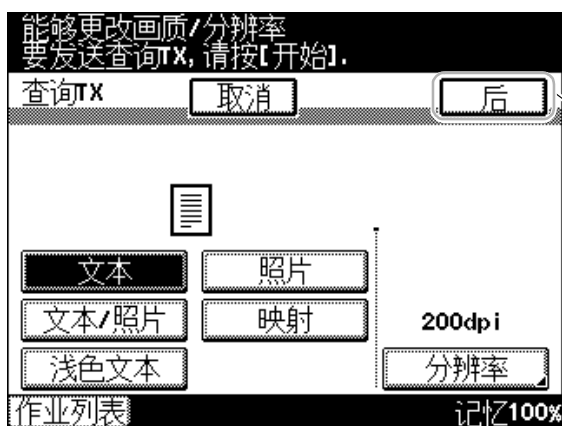
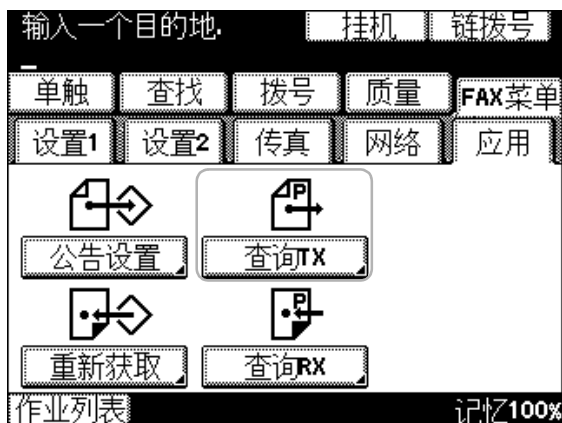

若要指定浓度和传送设置，触摸 [后]。



#### 细节

使用查询传送，接收者可节省传送成本。

若要请求机器发送使用查询传送保存的数据，触摸传真菜单选项上应用选项的 [查询RX]，然后指定发送者以便接收数据。



#### 备注

有关详细资料，请参见使用说明书 [网络扫描/传真/网络传真操作] 的第4章“传送数据”。

### 4.7 降低通信成本

使用深夜传送成本传送（定时器传送）

可以在白天指定目的地设置并扫描原稿，然后可以指定在电话费较低的深夜发送传送。

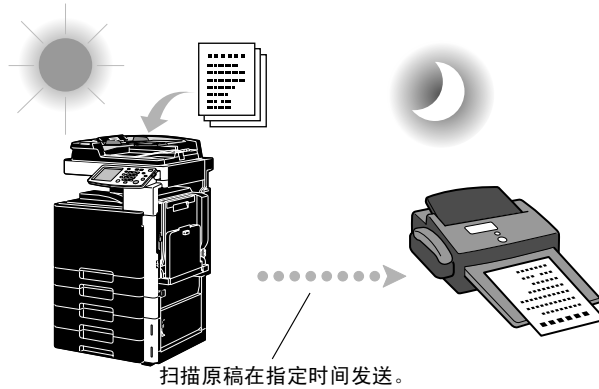

细节

为了在深夜发送传真，必须指定发送原稿时的定时器传送。



备注

有关详细资料，请参见使用说明书 [网络扫描 / 传真 / 网络传真操作] 的第4章“传送数据”。

#### 2合1传送

使用 ADF 扫描的两页文件可被缩小并以单页发送。

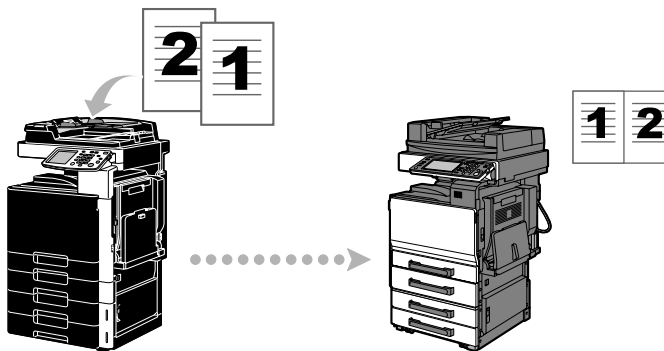

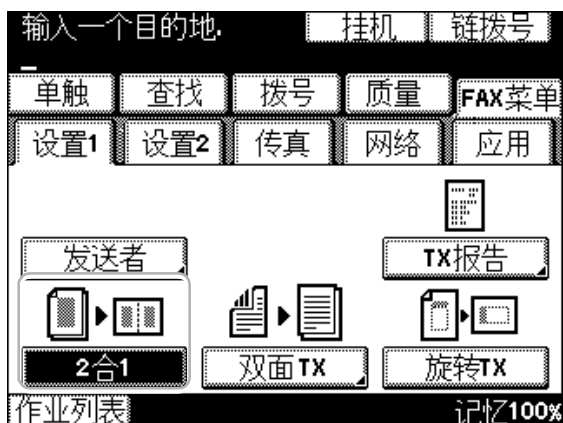

细节

2合1 传送只有在安装选购的ADF 时可用。

只有 A5、B5 和 A4 尺寸的文件可以使用 2 合 1 传送功能。



...

备注

有关详细资料，请参见使用说明书 [网络扫描 / 传真 / 网络传真操作] 的第 4 章 “传送数据”。

## 4.8 降低通信成本（使用 Internet/ 内联网）

### Internet 传真

使用 Internet，可以将扫描原稿作为电子邮件附件发送。

传送成本包括在 Internet 费用中。

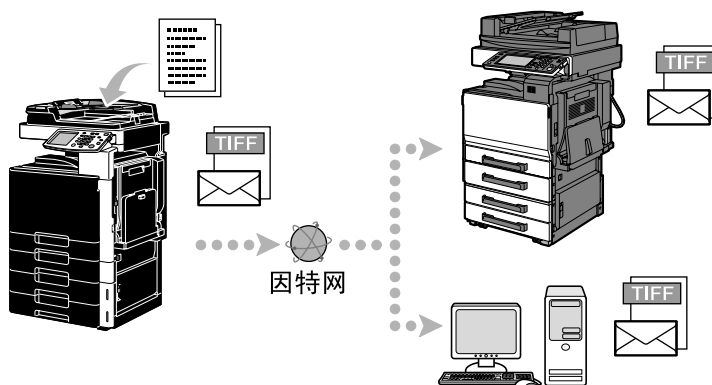

#### 细节

文件附件为 TIFF 格式。

即使扫描了彩色原稿，发送的数据也将是黑白的。

有关发送 Internet 传真的详细资料，请参见本说明书的第 4-23 页。

可以使用 Internet 传真之前，必须由管理员指定各种设置。

如果未安装选购的传真组件而且发生了停电或使用主电源开关将本机关闭，所有保存在存储器中收到的或发送的 Internet 传真数据将被删除。

例如，如果在缺纸时收到了 Internet 传真，数据会被保存在机器的存储器中而不会被打印。此时，如果使用主电源开关将本机关闭，存储器中的数据将被删除并且无法进行打印。



#### 备注

有关详细资料，请参见使用说明书 [网络扫描 / 传真 / 网络传真操作] 的第 1 章 “使用网络扫描 / 传真 / 网络传真功能之前”。

### IP 地址传真

可以选择目的地机器的 IP 地址，然后在公司内的内联网上发送传真。

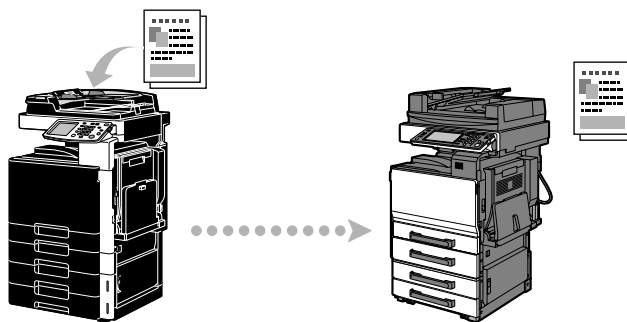

#### 细节

可以使用 IP 地址传真之前，必须由管理员指定各种设置。

IP 地址传真只可以在柯尼卡美能达兼容机型之间进行。其它兼容机型我们无法保证正确操作。



#### 细节

有关详细资料，请参见使用说明书 [网络扫描 / 传真 / 网络传真操作] 的第 1 章 “使用网络扫描 / 传真 / 网络传真功能之前”。

## IP 中继

传真可以通过连接到 LAN 的中继站发送。如果内联网中的中继站连接到电话线，则可以从任何一台连接到 LAN 的机器上发送传真。

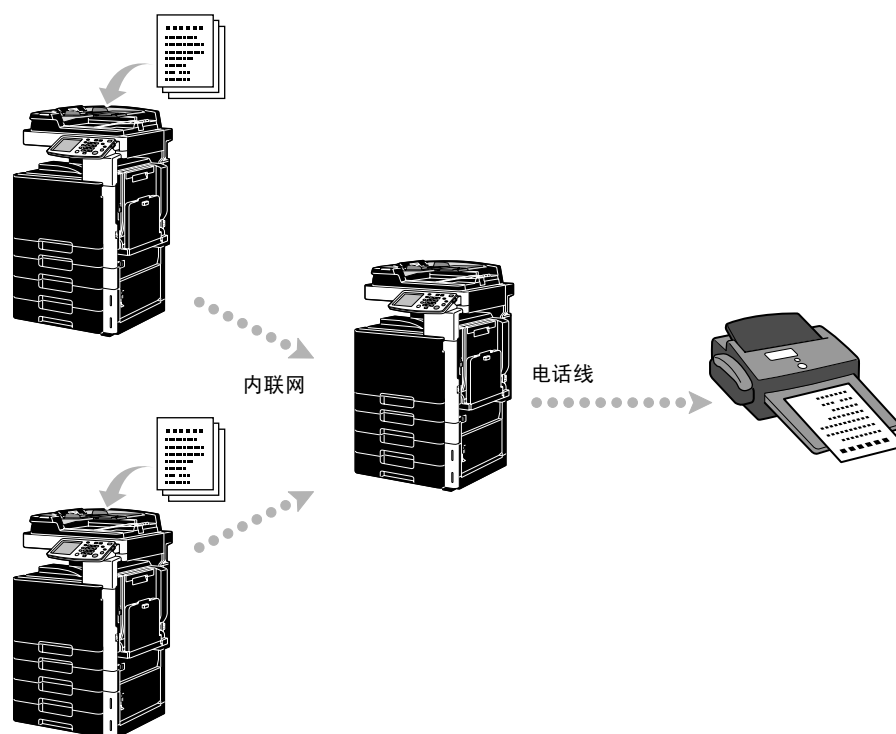

### 细节

数据可以使用 IP 中继传送发送之前，必须指定中继站设置和网络设置。



### 备注

有关详细资料，请参见使用说明书 [网络扫描 / 传真 / 网络传真操作] 的第 4 章 “传送数据”。

### 4.9 通过电子邮件发送原稿

#### Internet 传真

使用 Internet，可以将扫描原稿作为电子邮件附件发送。

传送成本包括在 Internet 费用中。

从单触键中选择

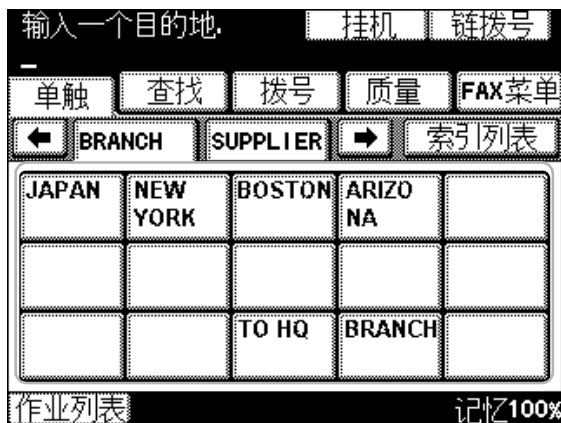

使用数字键盘输入目的地



为了发送互联网传真，请指定网络传真和互联网传真设置。

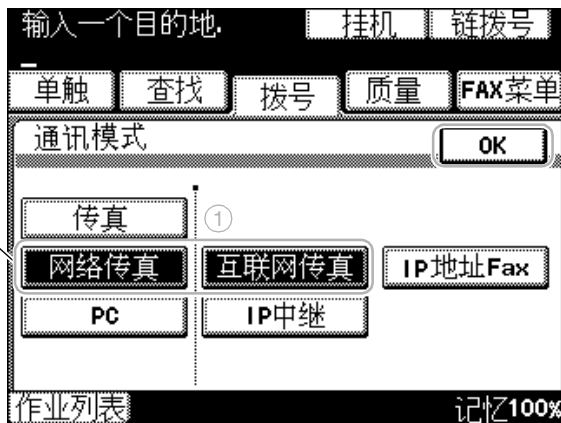



 ...  
备注

有关详细资料，请参见使用说明书 [网络扫描 / 传真 / 网络传真操作] 的第4章“传送数据”。



### 4.10 降低打印成本

#### 文件管理（记忆 RX）

接收到的传真可作为数据保存在用户 Box 中并在需要时打印。  
 在所有接收的传真文件中仅打印必要的传真文件可增强安全性并降低打印成本。

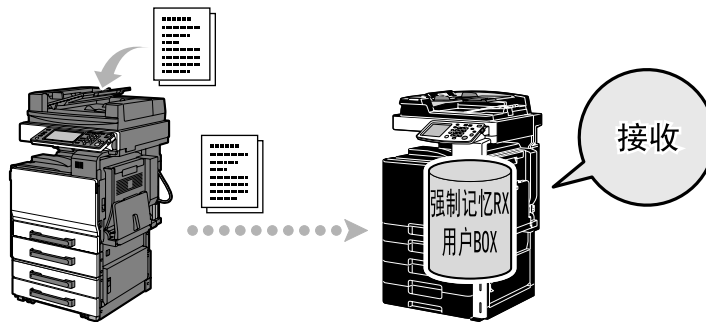

打印保存的传真数据

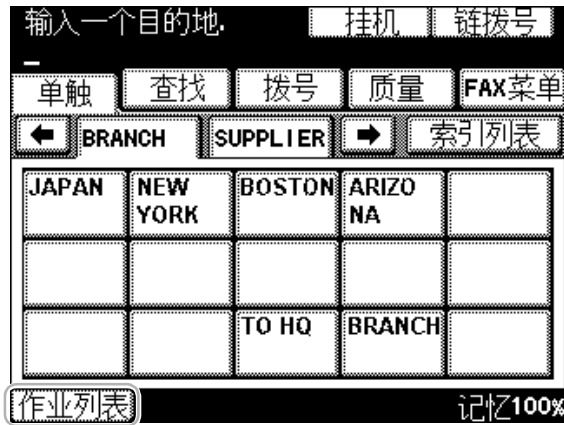



选择要打印的传真数据。



#### 细节

可以为 RX 文件用户 Box 指定密码。

从管理员管理屏幕中指定文件管理设置。指定设置时需要管理员密码。



#### 备注

有关详细资料，请参见使用说明书 [网络扫描 / 传真 / 网络传真操作] 的第 6 章 “有用的功能 (G3 / IP / I-FAX)”。

### 4.11 发送机密文件

#### F-码传送

发送文件时，除了传真号码之外，可以指定机密用户 Box (SUB) 和传送密码 (SID/PWD)，以保持文件的机密性。

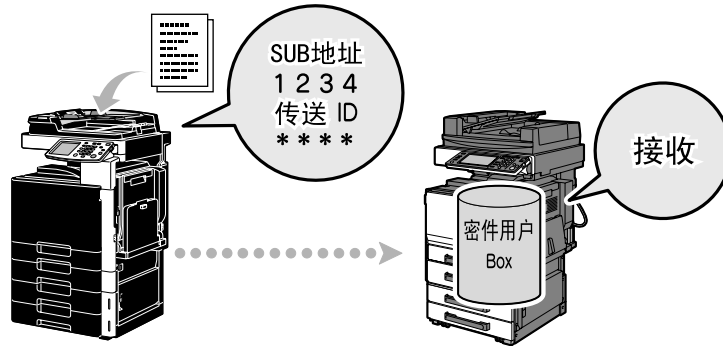

输入一个目的地 挂机 | 链拨号

单触 查找 拨号 质量 FAX菜单

F-码 OK

F-码 (SUB) 12345

F-码 (SEP)

F 码 p/w(SID/PWD) \*\*\*\*\*

作业列表 记忆100%



#### 细节

为了执行 F- 码传送，必须在收件人的传真机上指定机密 Box 和传送密码。  
只有收件人的传真机支持 F- 码功能时才可以使⤵用 F- 码传送。



#### 备注

有关详细资料，请参见使用说明书 [网络扫描 / 传真 / 网络传真操作] 的第 4 章 “传送数据”。

## 4.12 转发接收数据

### 文件管理（转发）

接收的传真数据可被转发到之前指定的目的地。

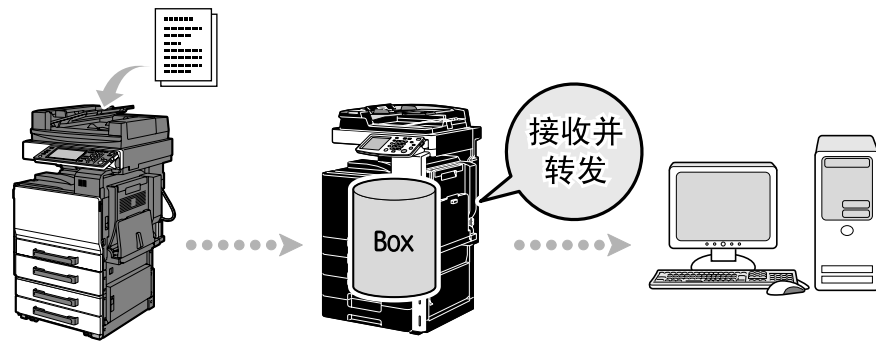

#### 细节

从管理员管理屏幕中指定文件管理设置。指定设置时需要管理员密码。  
在管理员管理屏幕中，也可以指定设置转发接收传真数据并使用本机打印数据。



...

#### 备注

有关详细资料，请参见使用说明书 [网络扫描 / 传真 / 网络传真操作] 的第6章 “有用的功能 (G3 / IP / I-FAX)”。

## 4.13 直接从计算机传真数据

## 计算机传真

在计算机上创建的数据可以使用相同的设置发送到目的地传真机，如同打印一样。

为了使用计算机传真，必须安装传真驱动程序。

可以指定传真文件设置。



可以从地址簿中选择目的地。



.....  
备注

有关详细资料，请参见使用说明书 [传真驱动程序操作] 的第3章“设置传真驱动程序 (Windows)”。

## 4.14 从计算机注册单触目的地

### Assistant tool

使用 Assistant tool，可以从计算机注册单触目的地和传真程序。

在网络浏览器的“地址栏”中输入本机的 IP 地址来使用 Assistant tool 与本机连接。

扫描就绪  
准备打印

管理员密码:

系统 作业 打印 传真/扫描

单触键登录  
传真程序登录  
域名注册

索引

Index1	Index2	---	---
---	---	---	---
---	---	---	---
---	---	---	---
---	---	---	---

注册索引:

<input type="checkbox"/> #000 abc	<input type="checkbox"/> #001 aaa	#002 ---	#003 ---	#004 ---
#005 ---	#006 ---	#007 ---	#008 ---	#009 ---
#010 ---	#011 ---	#012 ---	#013 ---	#014 ---

### 关于 Assistant tool

Assistant tool 是一种集成到本机中的设备管理实用程序。使用连接到网络的计算机上的网络浏览器访问 Assistant tool 以指定机器设置。

使用 Assistant tool 可以执行下列基本操作。

- 检查各种机器信息和打印机设置。
- 检查作业。
- 注册和编辑单触拨号目的地和传真程序。
- 注册 / 编辑账户。
- 指定各种机器环境、打印机、传送 / 接收和网络设置。



### 备注

有关详细资料，请参见使用说明书 [网络管理员] 的第 3 章 “Assistant tool”。





---

# 5

## 有用的网络扫描操作

## 5 有用的网络扫描操作

### 5.1 注册经常使用的目的地

可以注册经常使用的目的地。

#### 单触键

在单触键中注册经常使用的目的地，只要触摸一下单触键便可调出目的地。

*选择要编程的按钮*

#### 效用/计数器

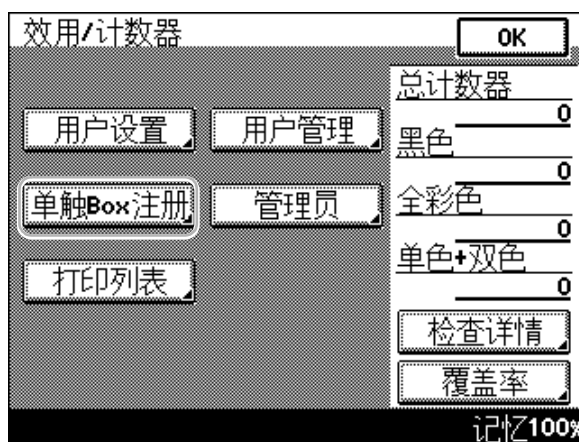
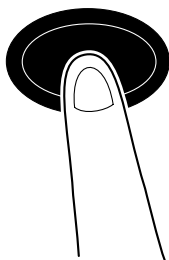

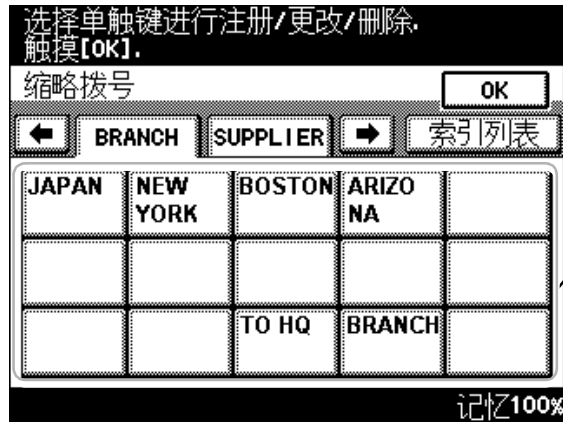
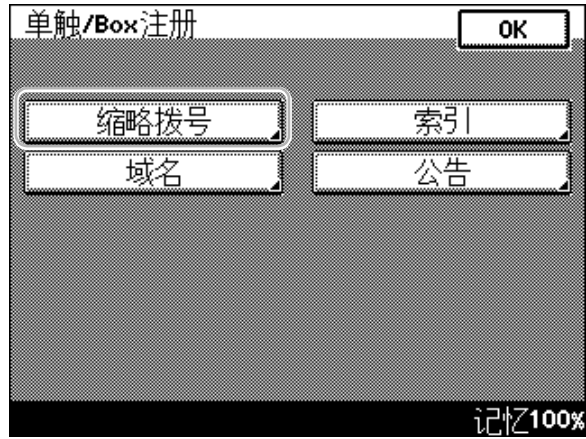

...  
备注

如果已注册了要搜索的LDAP服务器，可以将LDAP服务器上注册的地址注册为单触目的地。

注册电子邮件地址

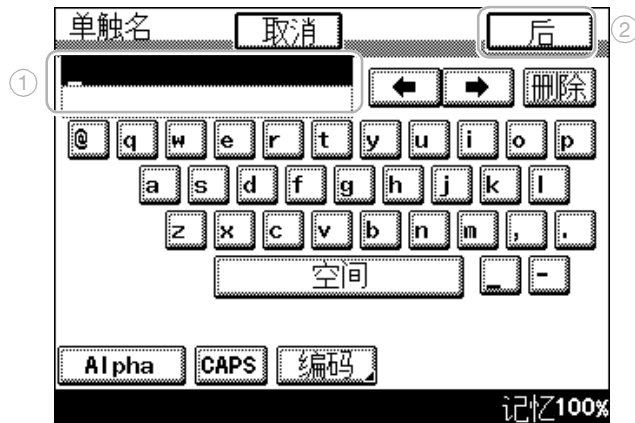

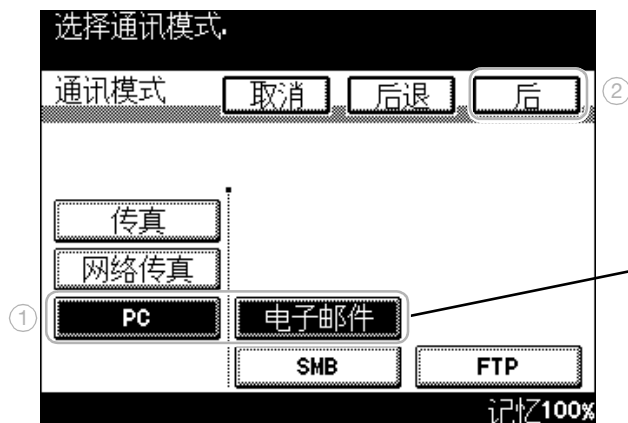

若要注册电子邮件地址，请指定 PC 和电子邮件设置。

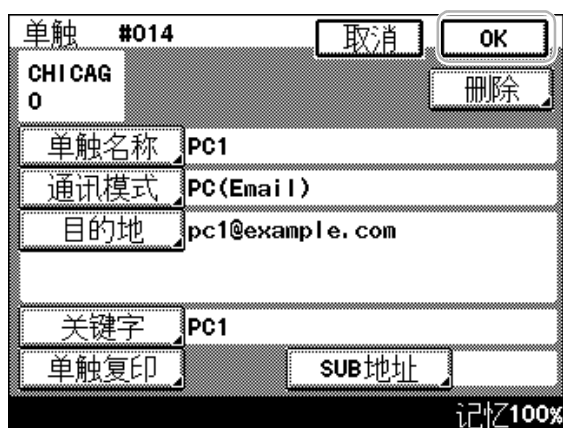

....  
备注

有关详细资料，请参见使用说明书 [网络扫描 / 传真 / 网络传真操作] 的第 2 章 “控制面板 / 触摸面板” 和第 8 章 “用户设置 / 用户管理 / 单触 / Box 注册”。

### 注册程序

只需一个按钮便可注册扫描设置、传送设置和目的地。



#### 细节

触摸单触拨号按钮可以指定目的地。

指定质量、传真菜单和拨号选项上的设置。



### 模式检查

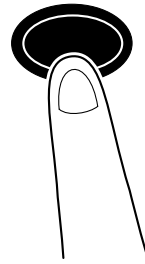

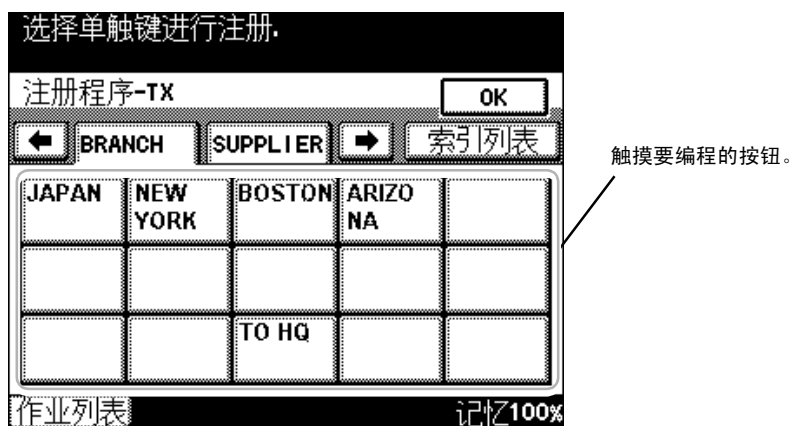

....  
备注

有关详细资料，请参见使用说明书 [网络扫描 / 传真 / 网络传真操作] 的第8章 “用户设置 / 用户管理 / 单触 / Box 注册”。

### 5.2 传送精细文字和清晰图像

扫描原稿时可以指定细节量（分辨率）和扫描方式（根据原稿包含文字还是图像）。高质量的原稿可以使用这些设置的组合来发送。

#### 调节分辨率

传送精细文字和图像时，指定较高分辨率可以发送更高质量的图像。

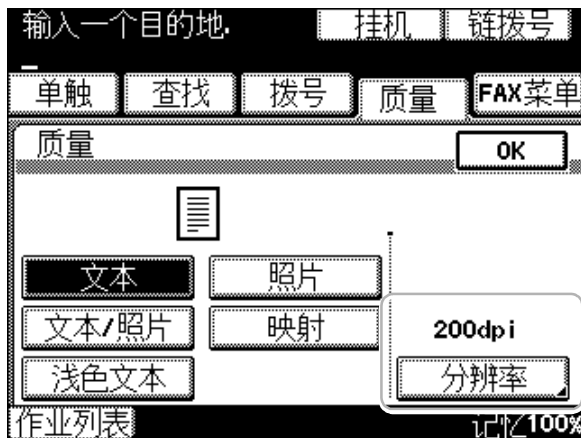
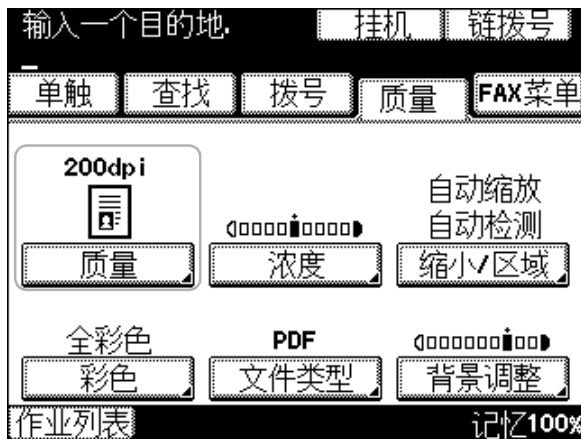
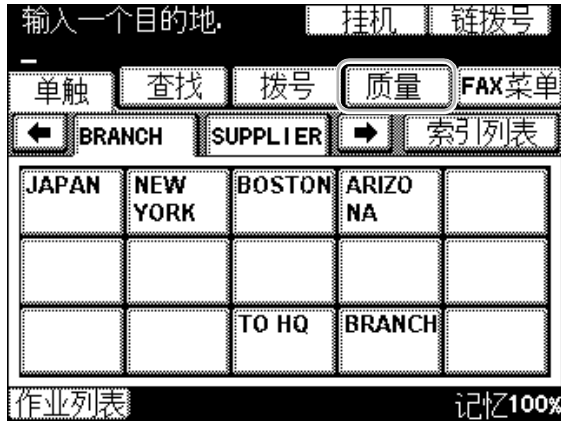

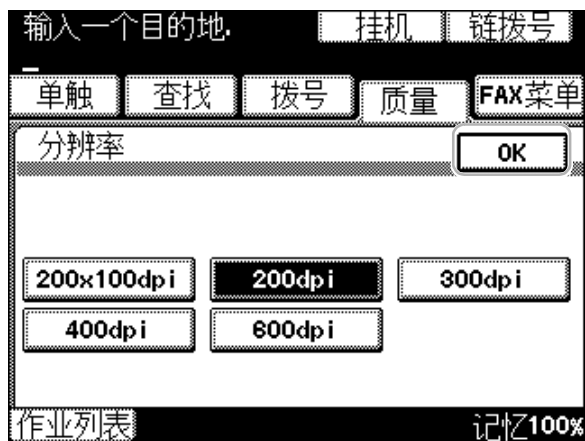

#### 细节

分辨率越高，数据会变得越大。



#### ... 备注

有关详细资料，请参见使用说明书 [网络扫描 / 传真 / 网络传真操作] 的第4章“传送数据”。



选择原稿类型设置。

选择适合原稿文本和图像类型的扫描方式。

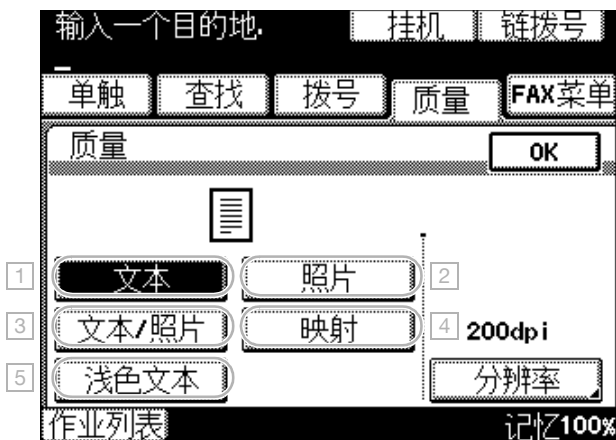
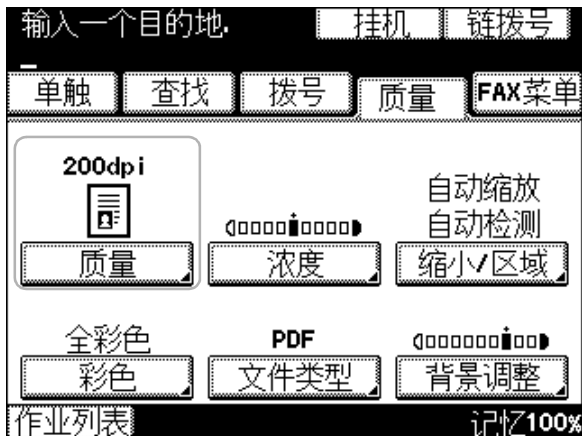

号码	参数	说明
1	文本	为仅包含文字的原稿选择该设置。
2	照片	为仅包含照片的原稿选择该设置。
3	文本 / 照片	为包含文字和照片的原稿选择该设置。
4	映射	为包含铅笔标记或精细彩色线条或有背景颜色的原稿，如地图，选择该设置。
5	浅色文本	为包含文字显得比较虚弱的原稿选择该设置。



...

备注

有关详细资料，请参见使用说明书 [网络扫描 / 传真 / 网络传真操作] 的第4章“传送数据”。

### 5.3 使用所选颜色和文件类型设置传送

选择颜色和文件类型设置

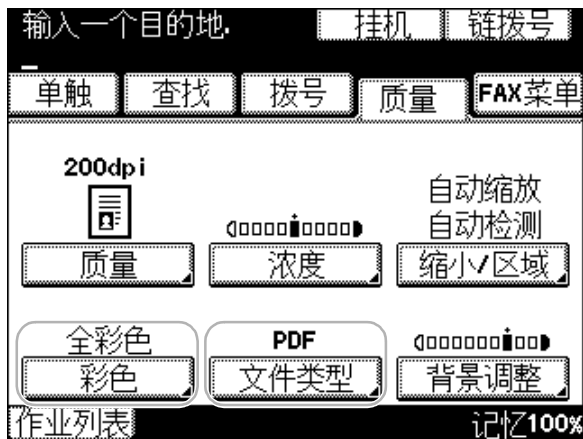

彩色

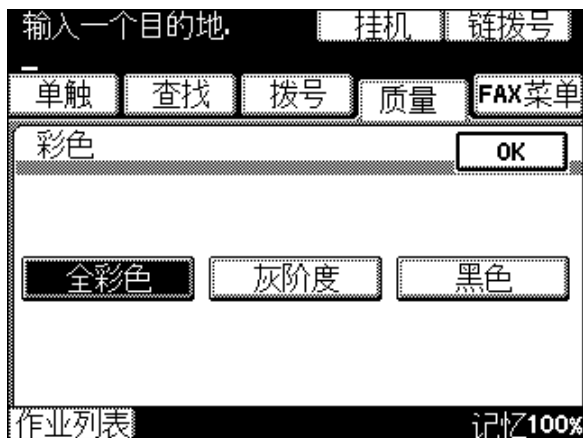

## 文件类型

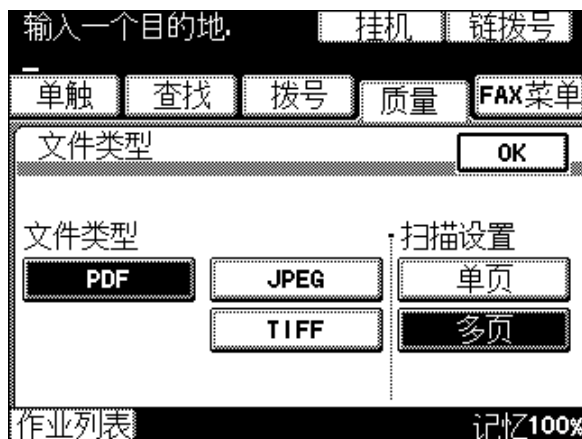

文件类型	说明
PDF	这种文件可以在 Adobe Reader 中显示。
JPEG	选择该设置将数据以 JPEG 格式保存。原稿每页都会创建一个文件。
TIFF	选择该设置将数据以 TIFF 格式保存。



...

## 备注

有关详细资料，请参见使用说明书 [网络扫描 / 传真 / 网络传真操作] 的第 4 章 “传送数据”。

## 选择文件类型和颜色设置

根据要扫描原稿的类型选择颜色设置。但是，根据所选的传送方式和文件类型设置，一些设置可能无法使用。

文件类型设置 颜色设置	PDF	JPEG	TIFF
全彩色	○	○	—
灰阶度	○	○	—
黑色	○	—	○

通过电子邮件发送数据时，或者在网络上传送数据时可以使用颜色设置。传真或使用 Internet 传真时无法使用颜色设置。



...

## 备注

有关详细资料，请参见使用说明书 [网络扫描 / 传真 / 网络传真操作] 的第 4 章 “传送数据”。

### 5.4 使用已调节背景颜色传送

#### 背景调整

扫描有彩色背景的原稿时，增亮背景可创建出更干净的扫描。

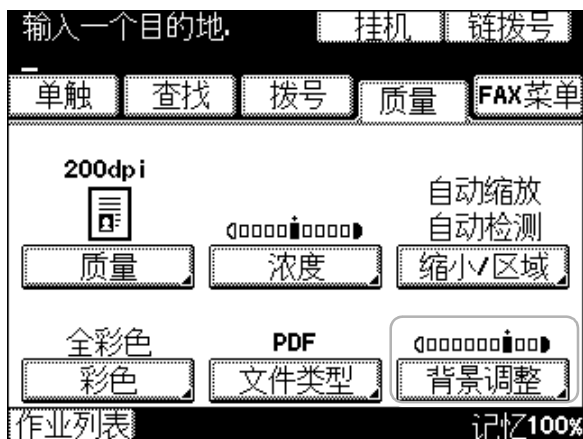

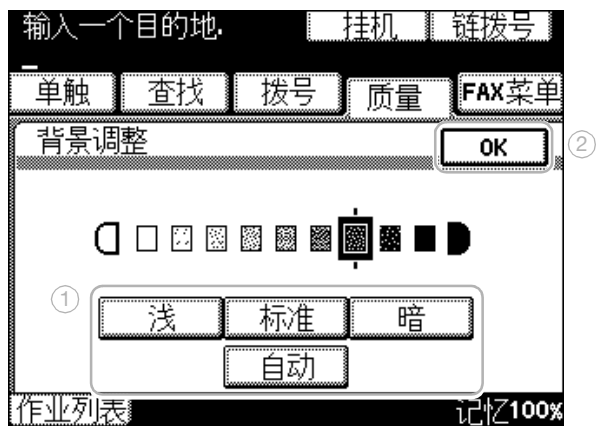

...  
备注

有关详细资料，请参见使用说明书 [网络扫描 / 传真 / 网络传真操作] 的第4章“传送数据”。

### 5.5 向多个收件人传送

搜索注册目的地

选择要发送数据的目的地。

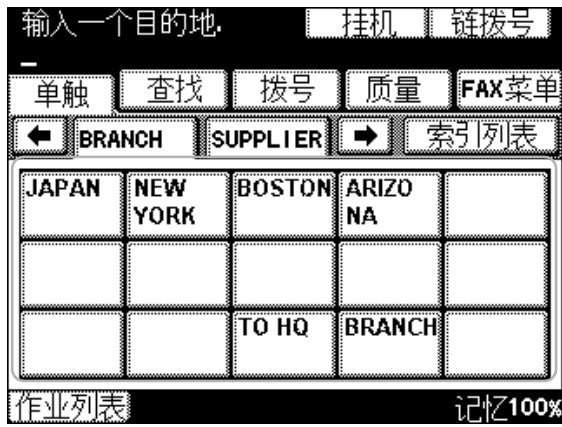

开始

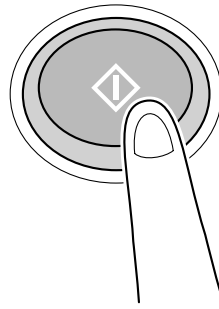



也可以从拨号选项中直接输入目的地。

可以搜索并选择注册目的地。

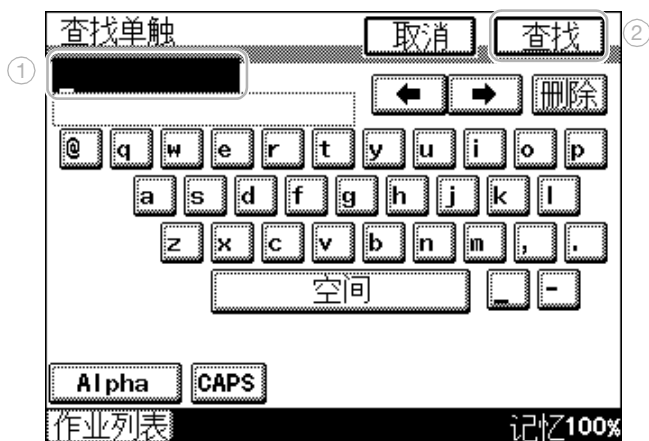
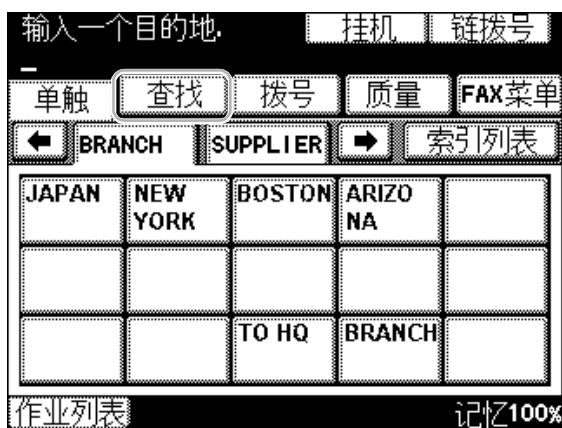





如果已在管理员模式中注册了 LDAP 服务器，则可以搜索在 LDAP 服务器上注册的目的地。有关注册和搜索 LDAP 服务器的详细资料，请参见使用说明书 [网络扫描 / 传真 / 网络传真操作]。

程序是之前一起注册的多个目的地，在选择目的地时非常有用。



**细节**

确认设置后，可以删除不需要的目的地或者将设置更改。



**备注**

有关详细资料，请参见使用说明书 [网络扫描 / 传真 / 网络传真操作] 的第4章“传送数据”。

## 5.6 通过电子邮件发送文件

### 电子邮件传送

指定电子邮件地址便可将扫描数据作为电子邮件附件发送。

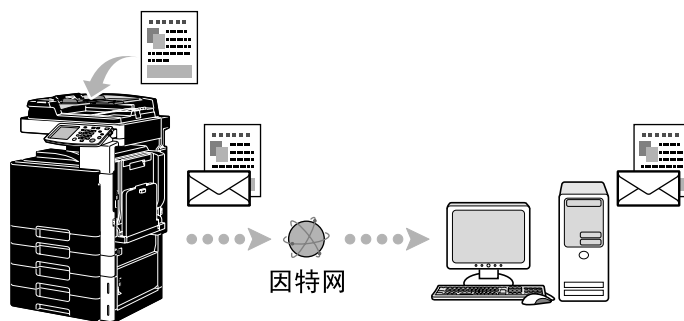

选择注册目的地，或者直接输入电子邮件地址。



备注

有关详细资料，请参见使用说明书 [网络扫描 / 传真 / 网络传真操作] 的第4章“传送数据”。

### 更改电子邮件主题或附件文件的名称

电子邮件的主题和文件名可在通过电子邮件发送扫描数据时更改。

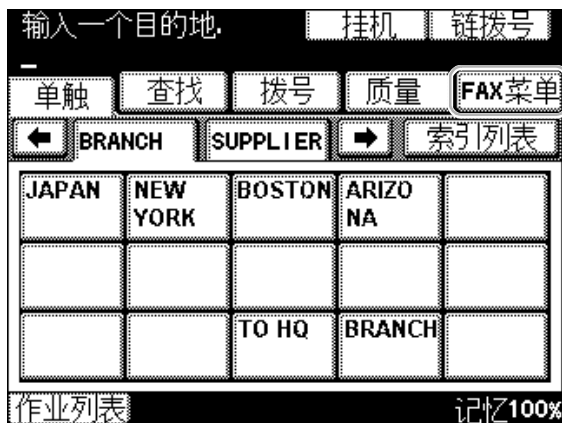

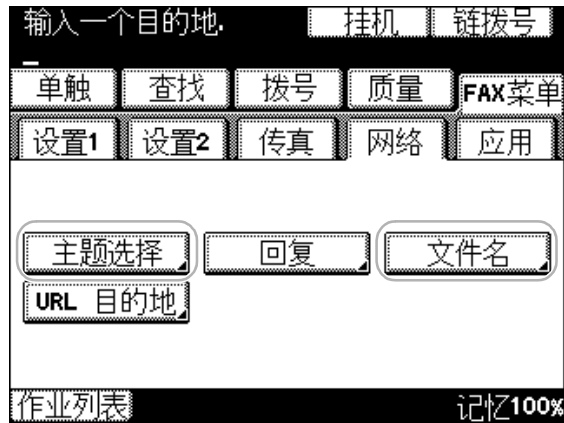
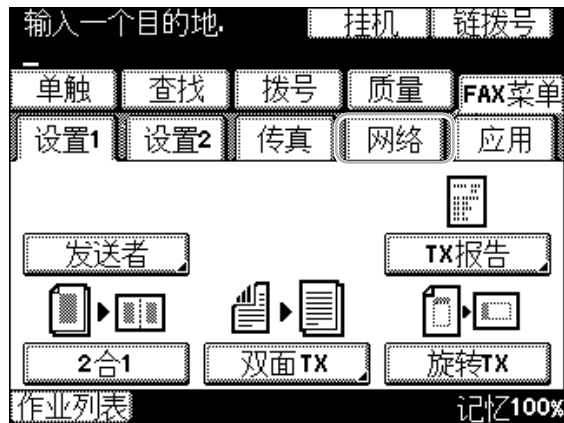

主题选择：可以更改电子邮件的主题。从管理员管理屏幕中注册主题。  
 文件名： 可以更改附件文件的名称。



备注

有关详细资料，请参见使用说明书 [网络扫描 / 传真 / 网络传真操作] 的第4章“传送数据”。

## 5.7 检查目前为止执行的传送

作业列表（类型）

显示传送作业的详细资料和传送结果。

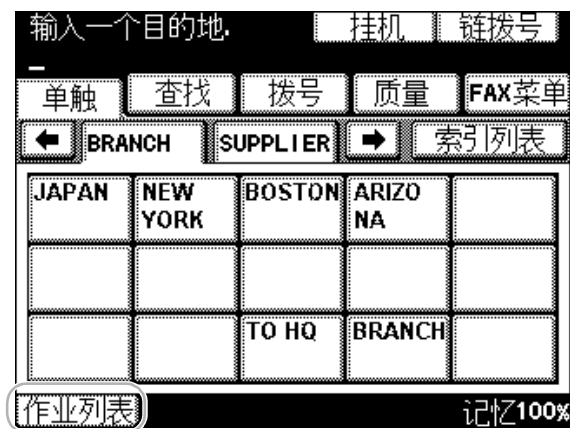

可以选择显示的传送作业。

RX 文档: 显示接收作业的详细资料和接收结果。



备注

有关详细资料，请参见使用说明书 [网络扫描 / 传真 / 网络传真操作] 的第2章“控制面板 / 触摸面板”。



---

# 6

## 故障排除

## 6 故障排除

### 6.1 故障排除

本章以问答形式介绍了普通的故障排除步骤。如果问题未能修正，即使在执行上述步骤后，请联系维修人员。

为什么无法打开机器？

本机有两个开关。

**答案**

请确认下列项目。

- 确认机器电源插头已牢固插入电源插座中。另外，确认电路断路器未发生滑动。
- 确认机器已使用辅助电源开关和主电源开关打开。

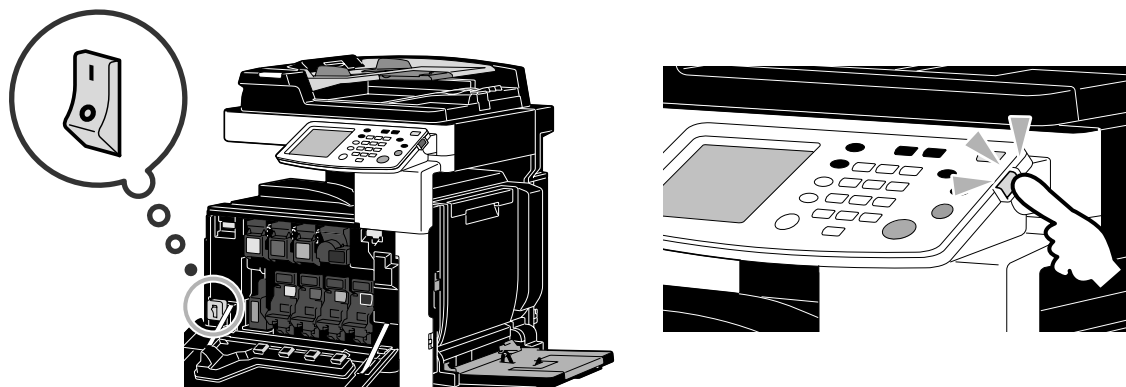

...  
提醒

如果在确认所示项目后机器仍未能打开，请联系维修人员。

为什么在触摸面板中未出现屏幕？

如在指定时间内未进行任何操作，则触摸面板熄灭并且机器自动进入节能模式。

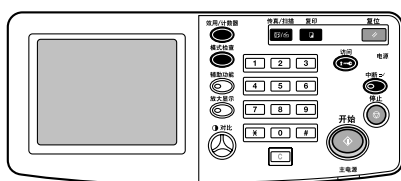



答案

请确认下列项目。

- 使用控制面板中的 [对比] 旋钮在触摸面板中调整屏幕的亮度。

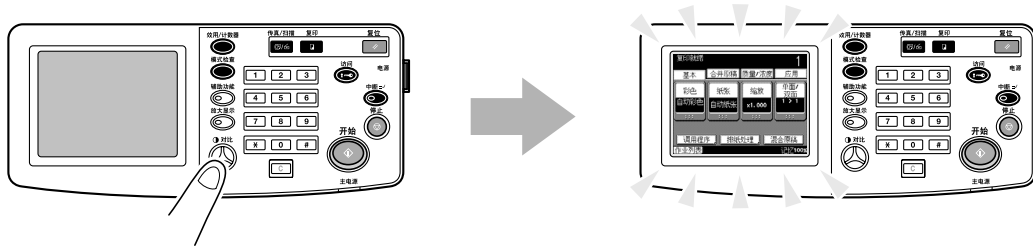

- 触摸触摸面板。如果触摸面板亮起，则说明没有问题。机器处于节能模式时，触摸触摸面板或者按下控制面板中的按键可取消节能模式。打开 ADF 或原稿盖板也会取消节能模式。

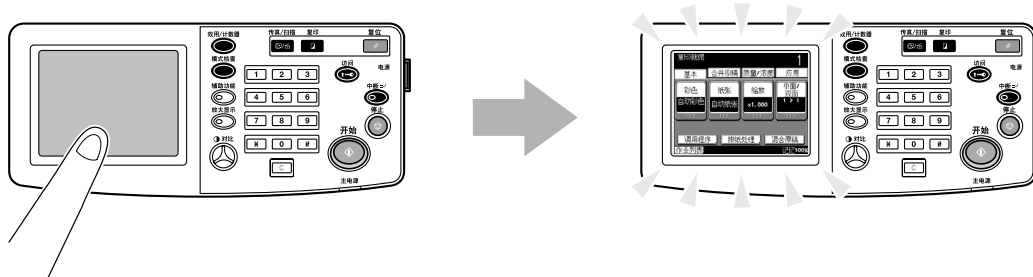

- 确认机器已使用辅助电源开关和主电源开关打开。

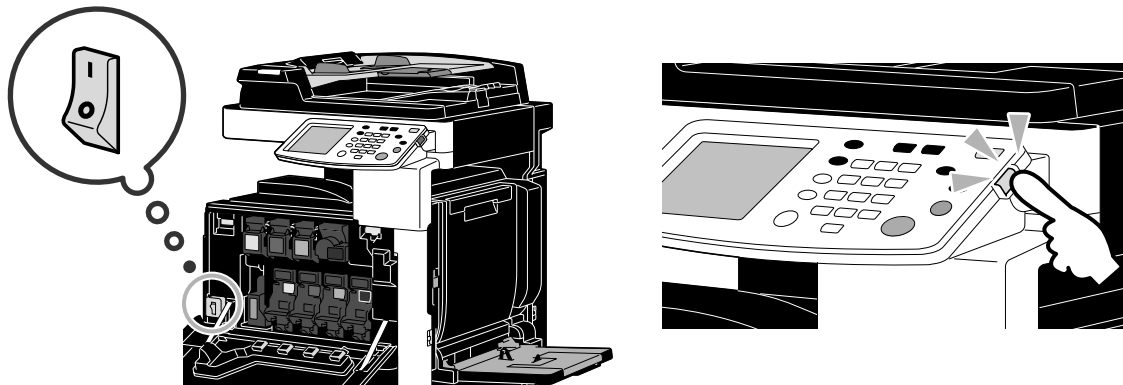

提醒

如果在确认所示项目后触摸面板中仍没有屏幕出现，请联系维修人员。

为什么出现必须更换耗材的信息？

本机使用的耗材即将用尽时，将出现有关更换期的警告。



#### 答案

请更换指定的耗材。

出现应更换耗材的信息时耗材即将用尽。出现该信息后可以在短时间内进行复印，但应尽快去准备耗材。

- 对于碳粉盒

出现信息“碳粉量 (X) 低。”后，会出现信息“更换粉盒。”。请根据维修协议更换碳粉盒。

- 对于成像组件

出现信息“需更换成像单元。”时，请根据维修协议准备更换成像组件。



提醒

如果在更换所示项目后仍显示该信息，请联系维修人员。

为什么仍会显示卡纸信息？

发生卡纸的位置可能在屏幕中所示位置之外。检查所示屏幕中的位置。

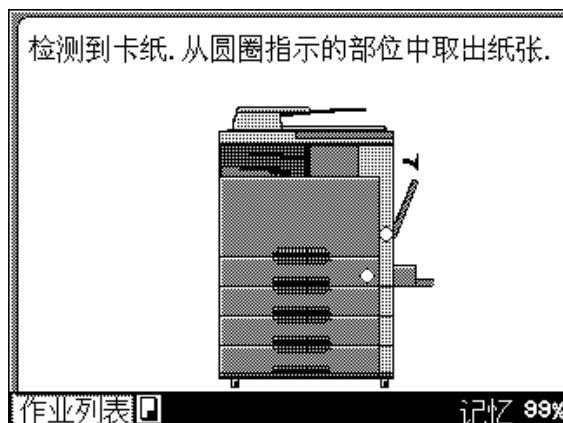

#### 答案

请确认下列项目。

- 确认在触摸面板屏幕中○所示部位没有破损的纸张。如果无法清除纸张，请联系维修人员。
- 打开，然后关闭触摸面板屏幕中○所示的门。执行过该操作后，该信息可能不会保持显示。



提醒

如果在检查所示项目后仍显示卡纸警告信息，请联系维修人员。

### 什么是图像稳定？

为了将本机保持稳定的颜色再现，本机具有可自动调整复印质量的功能。调整复印质量叫做“图像稳定”。



### 答案

进行大量复印后或者本机内温度或湿度发生变化时，便会执行图像稳定。

图像稳定完成时，请等待直到复印自动继续。



### 提醒

如果等待一段时间后图像稳定操作仍未完成，请联系维修人员。

### 为什么会出现错误信息？

如果用户无法修复出现的故障，则会出现信息“检测到故障。通知维修代表错误代码。”（呼叫维修人员屏幕）



### 答案

请注意屏幕中出现的故障代码，从电源插座中拔下机器电源线，然后联系维修人员。



---

# 7

## 用户设置参数

## 7 用户设置参数

使用用户设置参数，可以根据运行条件和环境更改普通机器设置和特定功能的设置。

### 7.1 显示用户设置屏幕

可以在用户设置屏幕中指定各种设置。

#### 效用/计数器

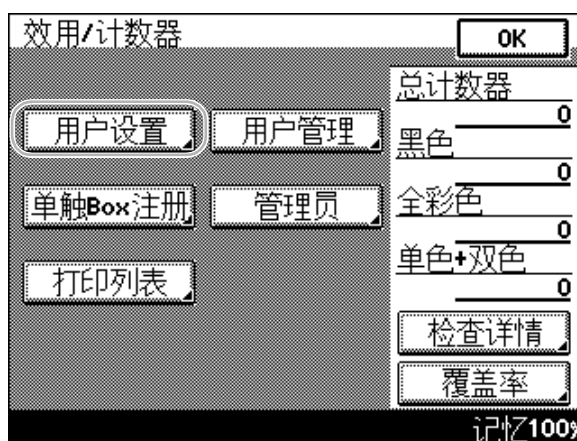
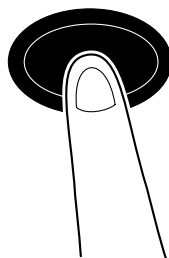

.....  
备注

有关详细资料，请参见使用说明书 [复印操作] 的第11章“效用模式”。

## 7.2 可以指定的设置

在用户设置屏幕上可以为下列六种类别的参数指定设置。

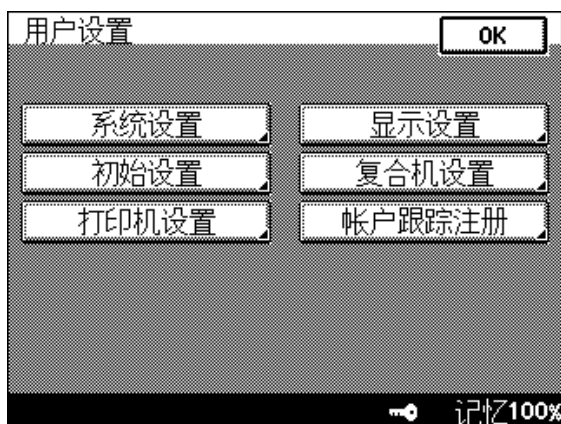

### 备注

有关复印机设置参数的详细资料，请参见使用说明书 [复印操作] 的第11章“效用模式”。

有关打印机设置参数的详细资料，请参见使用说明书 [打印操作] 的第11章“控制面板上的设置”。

### 系统设置

可以更改触摸面板的显示语言和度量单位。

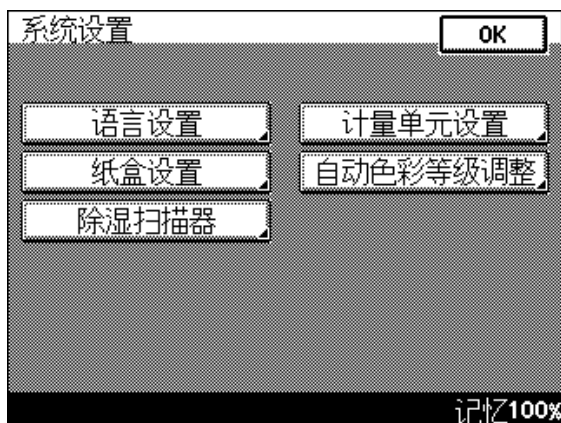

### 显示设置

机器运行之前显示的第一个屏幕叫做待机屏幕。可以选择待机屏幕的显示屏幕。



### 初始设置

可一个更改复印模式和传真 / 扫描模式中的默认设置。



### 复合机设置

可以更改复印功能的设置，这样便可以轻松执行各种操作。

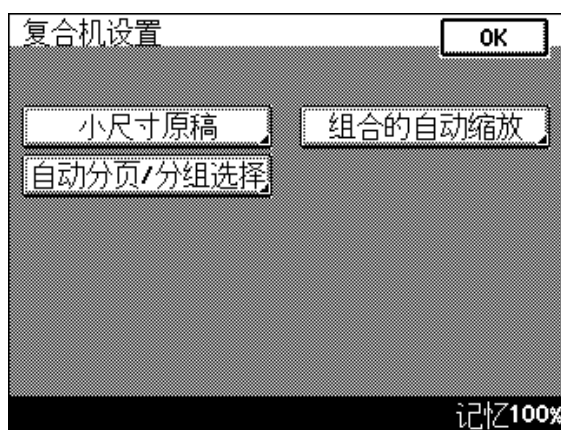



### 打印机设置

可以更改打印功能的设置，这样便可以轻松执行各种操作。



### 账户跟踪注册

已经指定账户跟踪设置并且用户已使用注册账户登录时，会出现该项目。可以为已登录的账户更改密码。根据所指定的软件开关设置，还可以更改 SMTP 认证密码和 POP3 密码。





---

# 8

索引

## 8 索引

## A

- Assistant tool ..... 4-31
- 安全警告主要事项和标签 ..... x-38
- 安全信息 ..... x-29

## B

- 背景调节 ..... 5-13

## C

- 查询传送 ..... 4-17
- 操作环境 ..... x-43
- 程序 ..... 2-10
- 程序目的地 ..... 4-5, 5-5, 5-15
- 传真 ..... 1-9
- 传真传送信息设置 ..... 4-13
- 传真转发 ..... 4-29

## D

- 打开 / 关闭 ..... x-50
- 单触键 ..... 4-2, 5-2
- 当前作业列表 ..... 5-20
- 低功耗模式 ..... 2-15
- 电源 ..... x-43
- 电子邮件传送 ..... 5-18
- 叠图 ..... 3-8
- 定时器传送 ..... 4-19

## F

- F- 码传送 ..... 4-27
- 放大 / 缩小 ..... 2-5
- 分辨率 ..... 5-7
- 分页 ..... 3-4

## G

- 更换成像组件 ..... x-68
- 更换废碳粉盒 ..... x-66
- 更换耗材 ..... x-63
- 更换碳粉盒 ..... x-65
- 故障排除 ..... 6-2
- 广播传送 ..... 4-9
- 光泽模式 ..... 3-9
- 规定注意事项 ..... x-33

## I

- Internet 传真 ..... 4-21
- IP 地址传真 ..... 4-21
- IP 中继 ..... 4-22

## J

- 机密打印 ..... 3-5
- 计算机传真 ..... 4-30
- 记忆 RX 用户 Box ..... 4-25
- 将纸张装入纸盒 1 ..... x-52
- 将纸张装入纸盒 2/3/4 ..... x-55

## K

- 空间要求 ..... x-42
- 控制面板 ..... x-49

## L

- LCD 背光关闭 ..... 2-15

## P

- 偏移 ..... 3-4

## Q

- 清除分离器中的卡纸 ..... x-62
- 清除卡纸 ..... x-60
- 清除主机中的卡纸 ..... x-61

## S

- 商标 / 版权所有 ..... x-3
- 手送进纸盒 ..... 2-7
- 双面打印 ..... 3-6
- 双面复印 ..... 2-2
- 睡眠模式 ..... 2-15
- 水印 ..... 3-8
- 搜索目的地 ..... 5-15
- 缩放 ..... 3-3

## T

- 通信列表 ..... 4-7
- 图像稳定 ..... 6-5
- 图像质量 ..... 3-9

## W

- 文件管理 ..... 4-25, 4-29
- 文件类型 ..... 5-11

## X

- 信封 ..... 2-7
- 选购件 ..... x-69
- 选择目的地 ..... 1-9, 1-12, 4-23
- 选择颜色 ..... 3-9

## Y

- 颜色 ..... 5-11
- 颜色设置 ..... 3-9
- 用户设置 ..... 7-2
- 用量计数器 ..... 2-13
- 原稿类型 ..... 5-7

## Z

- 账户跟踪 ..... 3-5
- 质量 ..... 4-15
- 质量调整 ..... 3-9
- 中继传送 ..... 4-19
- 装订边距 ..... 3-7
- 自动缩放 ..... 2-5
- 字体设置 ..... 3-10

组合 .....	3-6
组合复印 .....	2-2
作业列表 .....	5-20





**KONICA MINOLTA**

<http://konicaminolta.com>